

# BookletMac OPERATIONAL MANUAL

## INTRODUCTION

Congratulations on the purchase of your new **BookletMac**, a professional and heavy-duty booklet making machine. Your **BookletMac** was designed with a full range of function and premium quality components to guarantee you an effortless and professional job, as well as many years of trouble-free services.

## IMPORTANT

We recommend that you take a few minutes to familiarize yourself with the functions of your new **BookletMac**. You will find that with just a little practice, any person can achieve professional results.

## FEATURES

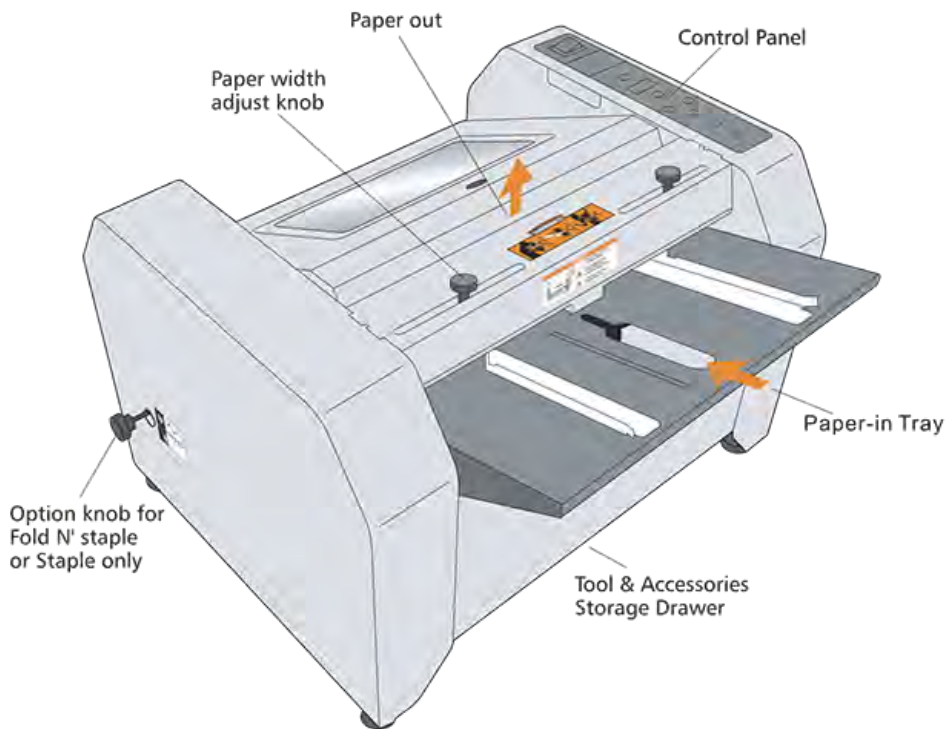

# ASSEMBLY & SAFETY

1. Place your new **BookletMac** on top of a sturdy working table.
2. Plug the power cord to the back of machine.
3. To reduce the risk of electric shock, never operate the **BookletMac** near water.
4. Do not use the **BookletMac** if power cord is damaged.
5. Do not allow the electric cord to be in contact with hot surfaces.
6. In case of malfunction, return the unit to your distributor for service. This equipment does not contain any part that can be serviced by the consumer or operator.

## OPERATION INSTRUCTIONS

1. Keep fingers, hair, jewelry, necktie and any loose clothing or objects away from the machine, as they may be accidentally pulled inside.
2. As part of its safety features, your BookletMac is equipped with sensors in various places of the machine. As a result, the machine will not work when the cover is open, the paper is not in position and no staple is inside the Stapler Head.
3. Clean the machine only by soft and damp cloth. Never use the chemical or alcohol base liquids as they may damage the rubber rollers or surface of your machine.
4. Lubricate the machine from time to time following the illustration below (lubricant is included in the tools drawer).
5. Only use our standard staples as others may damage your BookletMac.

### Electricity

- 115VAC / 60Hz
- 230VAC / 50Hz

### Tools & accessories delivered with this machine.



1 universal Wrench (works as a Stapler Head screw driver, staples picker and staples remover).



1 bottle of lubricant



2 Staple Pushers for spare replacement.

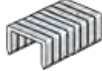

1 box of our standard staples, 26/6, 5,000 pcs per box



# SET UP FOR FOLD & STAPLE

1. To make booklets that are folded in the middle and stapled, set your "Paper Stop Knob" & "Option Knob" as shown in illustration A below.
2. To make top or side staples on your sheet only (without any fold), set your "Paper Stop Knob" & "Option Knob" as shown in illustration B below.
3. To make folds on your sheet only (without any stapling), set your "Paper Stop Knob" as shown in illustration B, and "Option Knob" as shown in illustration A below.

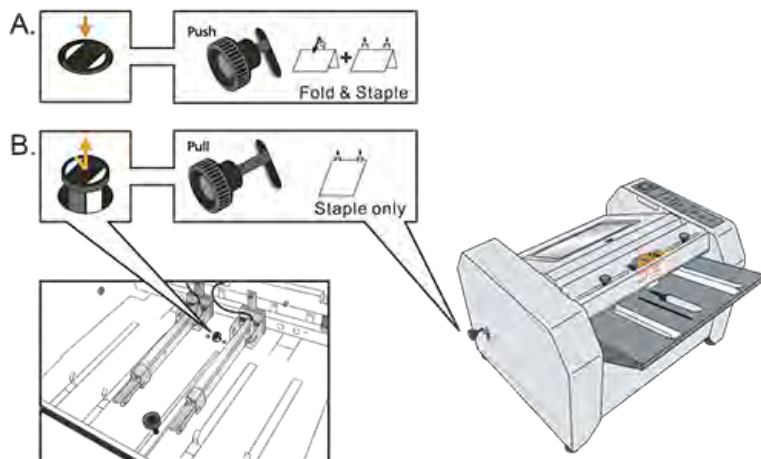

# SET UP FOR STAPLER HEADS

The **BookletMac** comes with 2 **Stapler Heads** positioned at 108mm apart from each other, which is suitable for most booklet formats from 5-1/2"x 4-1/4" (or A6 size) up to Letter size (or A4 size). For booklets larger than Letter size, you can choose to purchase 1 or 2 more **Stapler Heads**, or set your **Stapler Head** positions further apart, for a more secure and professional booklet. Contact your dealer for more information. Follow the steps in next page to install / remove **Stapler Heads**.

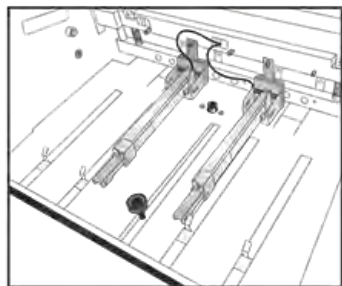
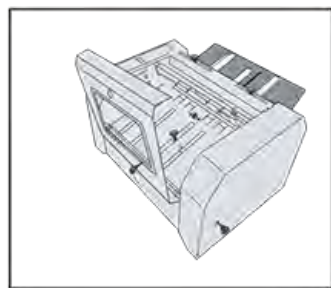
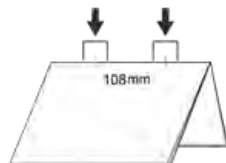

# MOVE STAPLER HEADS

Following the steps below if you wish to remove/install **Stapler Heads** at different positions.

- A. Turn the latch counter-clockwise to position 1. to unlock the **Stapler Head**.  
Unplug the cord socket from **Stapler Head**.
- B. Remove **Stapler Head** and insert it in a different **Stapler Head** position.
- C. Make sure the hole on **Staples Pusher** is hinged onto the pin, and the mark "26" on the **Staple Pusher** is shown towards the rear of the machine. Turn the latch clockwise to lock it, and plug in the cord socket back to **Stapler Head**.

## **IMPORTANT:**

- aa. To avoid problems during operation, the hole of the **Staples Pusher** must be hinged onto the pin, with the mark "26" shown towards the rear of the machine.
- bb. The latch must be securely locked onto **Stapler Head**. Otherwise, the **Stapler Head** may fall out during operation and cause the machine to be seriously damaged

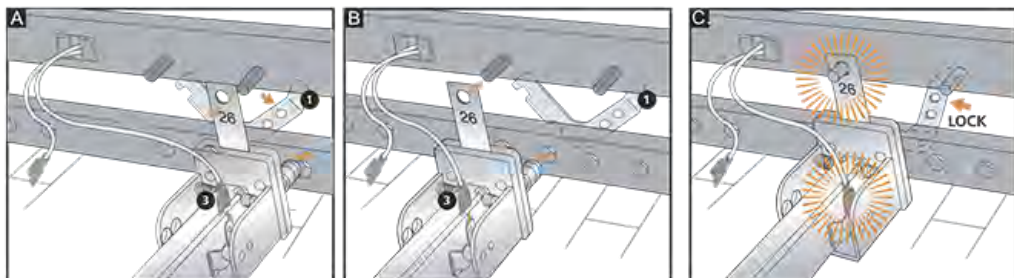

## **TIPS to remove jammed staples from Stapler Heads.**

Repeat the above steps to remove **Stapler Head** from machine, then use the **Universal Wrench** to unscrew the front plate of **Stapler Head**. Remove jammed staples and clean it. Screw the front plate back onto the **Stapler Head**. Repeat above steps to install **Stapler Head** back to machine.

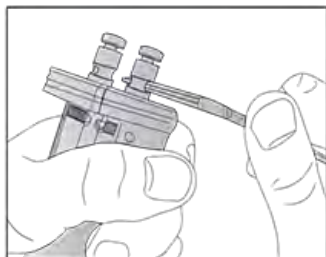

## **TIPS to replace new Staples Pusher**

The **Staples Pusher** should be replaced from time to time to ensure an efficient and smooth stapling operation. If staple jams occur more frequently than usual, or a abnormal stapling sound occurs during operation, follow the steps above to remove **Staples Pusher** and check if it is scratched or worn out.

To purchase new **Stapler Pusher** ( Part # CS2-80-3), contact your dealer. Then, follow the steps as above to replace the **Staples Pusher**.

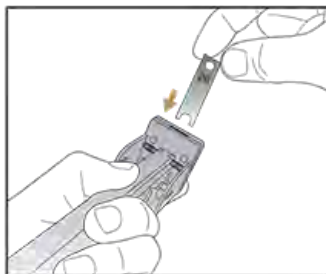



# LOAD STAPLES

1. Pull the staples magazine cap backwards until it is locked in place.
2. Open staples magazine cover.
3. Load staples (Must use our standard 26/6 or 26/8 staples).
4. Close magazine cover and gently unlock the staples magazine cap and push it towards the machine's front side. Do not let the staples magazine cap to snap forward, as it would smash the stick of staples.

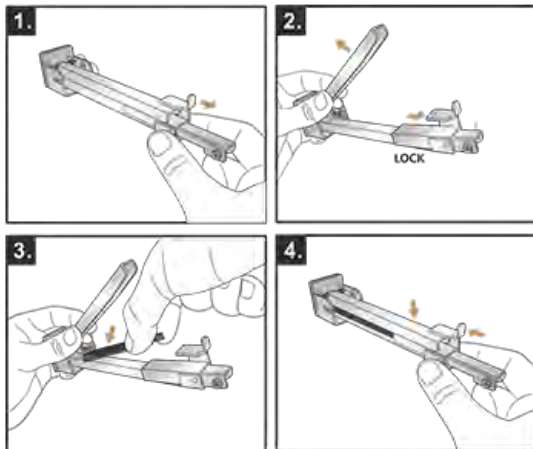

## **IMPORTANT:**

Use only our standard staples on the right. Other Staples may damage our Stapler Head or lead to bad results.

The No-Staple light will be turned ON when there are only 5 staples left in the Staples Magazine. Also, machine will stop working at this point. Remove last 5 staples and refill staples to stapler magazine following the above instructions (Maximum 210 staples per load).

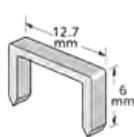

Part # CS 266,  
26/6 Staples  
5,000 pcs/box

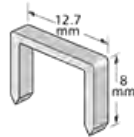

Part # CS 268,  
26/8 Staples  
5,000 pcs/box

## **TIPS**

Some defective staples may fall inside of machine. Use the magnetic **Universal Wrench** to pick them up from inside of the machine as needed.

Our **Universal Wrench** can also be used as a staples remover.

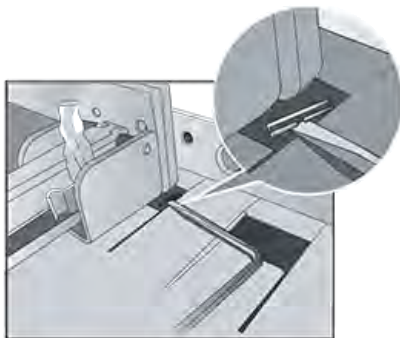

# ADJUST PAPER WIDTH & LENGTH

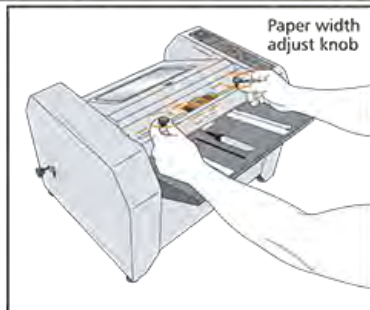

1. Adjust the **Left Side Guide** to the proper position on the paper scale sticker, according to your sheet format. Secure it with the knurled screw.
2. Insert paper, then squaring it up parallel to the **Left Side Guide**.
3. Adjust the **Right Side Guide** next to the inserted paper, leaving approximately 1mm of space so that the paper can slide in and out easily & smoothly.

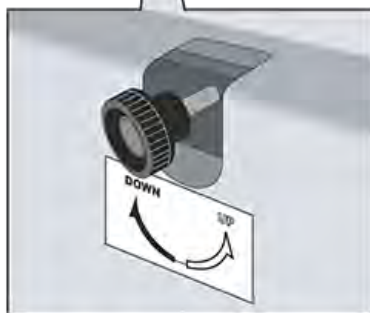
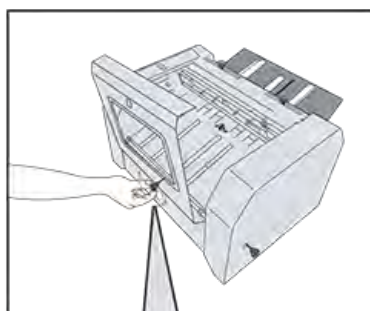
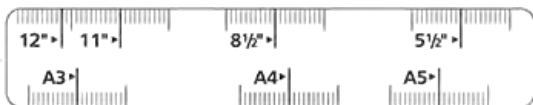
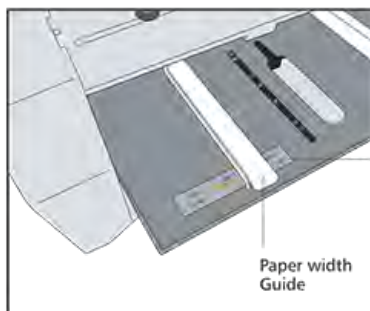

**A5** To adjust the Paper Length.

1. Open the machine cover and adjust Paper Depth Adjustment Knob to the proper position, according to your sheet size. Then close cover to test fold a few sheets manually.
2. Center the folding line of your booklet by turning the Paper Depth Adjustment Knob and making small adjustment on it.

8 1/2"

11"

A4

14"

A3

17"

18"

- Minimum sheet sizes: A5 (or 4-3/4" x 8-1/4")
- Maximum sheet sizes: A3 (or 12-1/2" x 17-3/4")

- Minimum of booklet sizes: A6 (or 4-1/8" x 4-3/4")
- Maximum of booklet sizes: A4 (8-7/8" x 12-1/2")

# FEEDING PAPERS

1. Insert flat sheets at **Paper-in Tray** and align it to the **Left & Right Side Guides**, making sure the sheets are squared up correctly. Press **"MANUAL START"** button on control panel, then the sheets will be slide into the machine and booklet will be produced from **Paper-out**.



2. Make slight adjustments to the **Left & Right Side Guides**, **Paper Depth Adjustment Knobs** or **Stapler Head** positions until the satisfactory booklet come out. Then press the **"AUTOMATIC"** button and reset the **"COUNTER"** to zero, so you can feed in papers continuously. **NOTE:** When the operation mode is set on **AUTOMATIC**, machine will start automatically in 2 seconds after sheets are inserted into the **Paper-in Tray**.

- Allows maximum 22 sheets for 20lbs(75gsm) paper per run.
- Productivity: up to 800 booklets per hour.



## FOLD AND STAPLE ALIGNMENT

Sometimes the location of the fold will need to be adjusted to achieve perfect alignment with the staples. Please follow these instructions to adjust the location of the fold:

1. Test a booklet to make sure the staples and fold are in alignment. If not, go to Step 2.
2. Open and remove the side door on the left panel of the machine.
3. Unlock the fold adjustment by turning Knob A counter-clockwise.
  - a. To move the fold TOWARDS the feeding tray, turn Knob B clockwise.
  - b. To move the fold AWAY from the feeding tray, turn Knob B counter-clockwise.
4. Turn Knob A clockwise to lock the fold adjustment.
5. Test a booklet to make sure the staples and fold are in alignment. If alignment is off, repeat Step 2. If alignment is correct, go to Step 6.
6. Re-attach and close the side door.

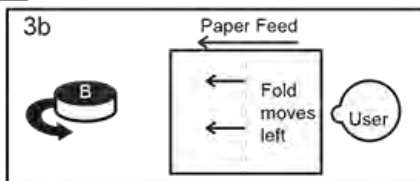
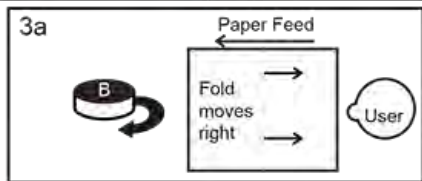
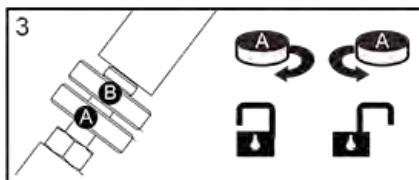
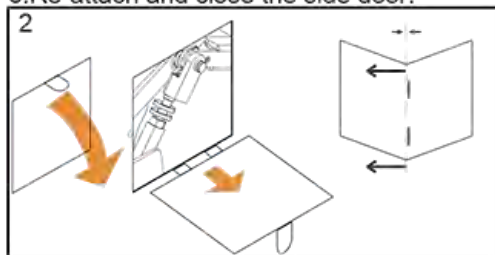

## Troubleshooting

### Machine is switched on, but it won't work at all.

|  |  |
|--|--|
| The power cord is not plugged in properly. | Push power cord thoroughly into power outlet.  |
| Cover is open.                             | Close cover.   |
| No-Staple light is ON.                     | Re-fill Staples. Follow instructions on Page 4.  |
| Papers are not in Paper-in Tray.           | Place paper on Paper-In Tray and align to the Left & Right Side Guides.  |
| Staples jam.                               | <ol style="list-style-type: none"> <li>1. Remove jammed staples. Follow instructions on page 3.</li> <li>2. Always use our 26/6 or 26/8 standard staples.</li> <li>3. Check if Staples Pusher is scratched or worn out. Follow instructions on page 3 to put in a new Staples Pusher.</li> </ol>   |
| Paper Jam.                                 | <ol style="list-style-type: none"> <li>1. To remove jammed sheets, press the "REVERSE" button on control panel to drive paper backward. You may need to press it a few times until it stops, then you can pull out jammed sheets.</li> <li>2. Do not insert more than 22 sheets for 20lbs (75gsm) paper.</li> <li>3. Do not insert materials that are too thick or too rigid sheets. Do not insert materials other than papers.</li> </ol> |
| Black (Dark colored) Covers.               | If possible, avoid using black or dark colored covers, as the infrared sensor may not be able to detect sheets being inserted into the machine.  |

### Machine does not staple although the staple magazines are fully filled with staples.

|   |  |
|---|--|
| Staple Pusher is not hinged onto the pin.           | The hole on the Staple Pusher should be hinged onto the pin. Follow instructions on Page 3.  |
| Staple Pusher is missing or incorrectly positioned. | Follow instructions on Page 3 to put in Staples Pusher. The mark "26" should be shown towards the rear of the machine and the Stapler Head latch should be locked. |

### Missing staples or un-qualified staple output.

|   |   |
|---|---|
| Unqualified staples.                          | Use only our standard 26/6 & 26/8 staples. See page 4.  |
| Incorrect staples type or specification.      | Use only our standard 26/6 & 26/8 staples. See page 4.  |
| Stapler Pusher is put in the wrong direction. | The Stapler Pusher should be shown towards the Left rear of the machine. See Page 3   |
| Residues inside Stapler Head.                 | Remove the Stapler Head from the machine, unscrew the front plate of Stapler Head, clean Stapler Head and re-install the Stapler Head to the machine. Make sure the Stapler Head latch is locked before you operate the machine. Follow the instructions on Page 3 to remove/install Stapler Heads. |
| Stapler Pusher is scratched or worn out.      | Follow the instructions on Page 3 to change Staples Pusher.   |

### Cannot fold or un-qualified booklet fold & staple.

|   |   |
|---|---|
| Settings for the Fold & Staple features are not correctly set.                      | Follow instructions on page 2 to set-up the Fold & Staple features correctly.   |
| Too many sheets are inserted or the material is too rigid.                          | <ol style="list-style-type: none"> <li>1. Do not insert more than 22 sheets for 20lbs (75gsm) paper per run.</li> <li>2. Do not insert materials that are too thick or too rigid sheets. Do not insert materials other than papers.</li> </ol>  |
| Folding line is not located in the center of the booklet, or is at a slanted angle. | <ol style="list-style-type: none"> <li>1. Properly adjust the Left &amp; Right Side Guides. If the Side Guides are too far apart, paper can be unparallel as it is inserted into the machine. On the other hand, if the Side Guides are set too lightly, paper can curl up during folding, which results in incorrect stapling. See Page 5 for instructions.</li> <li>2. Properly adjust the Paper Depth Adjustment Knob, so the machine folds in the center of the sheets. See Page 5 for instructions.</li> </ol> |
| Dirty rollers.  | Clean rollers by soft and damp cloth. Never use chemical or alcohol base liquids as they may damage the roller.   |
| The 2 staples are not properly centered in the booklet.                             | <ol style="list-style-type: none"> <li>1. Properly adjust the Left &amp; Right Side Guides. See Page 5.</li> <li>2. Re-install Stapler Heads to the correct positions. See page 3.</li> </ol>   |

1 Year limited Warranty - Contact Finitura 800-886-2463

**FINITURA**  
FINISHING AT ITS FINEST

CS2-P15(US)