

Akiles FlexiCloser Operation Manual

INTRODUCTION

Congratulations on the purchase of your new FlexiCloser, a professional and heavy-duty electric wire closing machine. Your FlexiCloser was designed with a full range of functions and premium quality components to guarantee you an effortless and professional bind, as well as many years of trouble-free service.

IMPORTANT

We recommend that you take a few minutes to familiarize yourself with the functions of your new FlexiCloser. You will find that with just a little practice, any person can achieve professional results.

HIGHLIGHTS

- World's first SMART-DETECT wire closing system, eliminating the cumbersome procedure to manually adjust & set-up a machine for different wire sizes.
- Included MICRO-ADJUST FEATURE guarantees a perfect wire closing result with all wire types and brands.
- Included SAFETY SENSOR FEATURE protects the operator's hands from being accidentally injured by the closer.
- Included HIGH EFFICIENCY MODE allows closing plate to only return half-way after closing a small wire (3/16" to 9/16"), to reduce the wire closing distance and operation time. This feature can be enabled or disabled by the operator at any time.
- The wire closing range is designed to close all types of wires, from 3/16" to 1-1/2", in either 3:1 or 2:1 pitch.

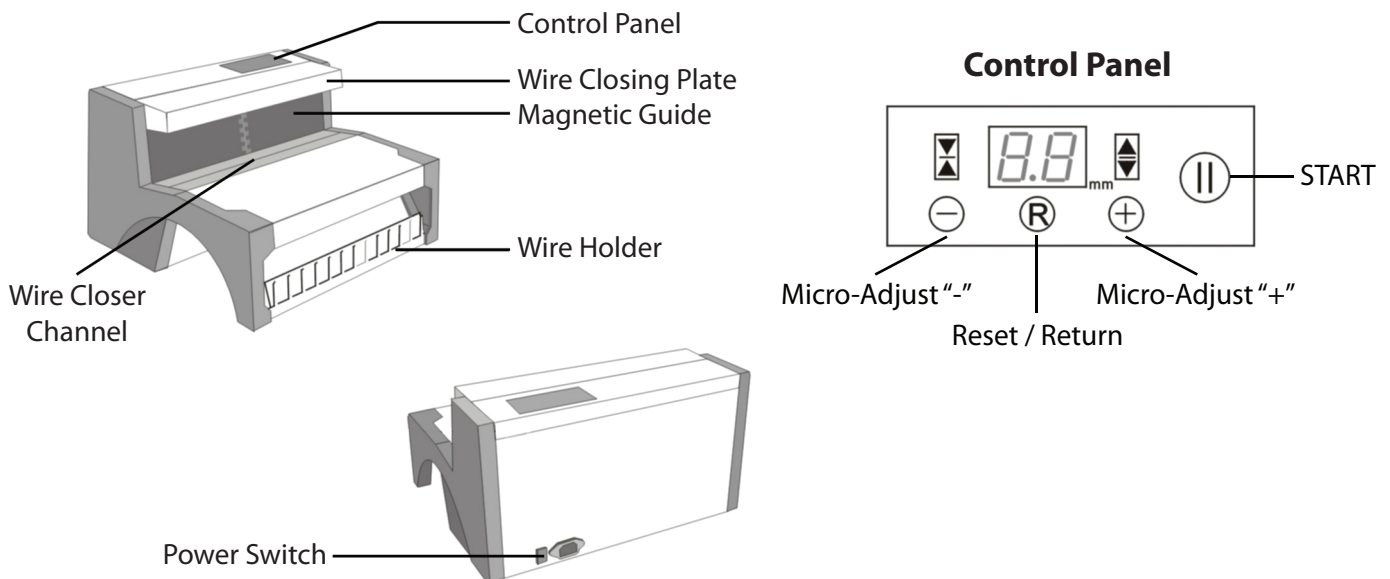

INSERTING

1. Insert pre-selected wire into Wire Holder.
2. Insert documents from the last page to the first page, and then insert the front cover.
3. The back cover should be inserted last, with the inside facing up.
4. Take out the unbound book from the Wire Holder by lifting the wire upward. Be careful to not let the pages fall out of the wire.
5. TIP: The seam of the closed wire should be inside the back cover of your book.

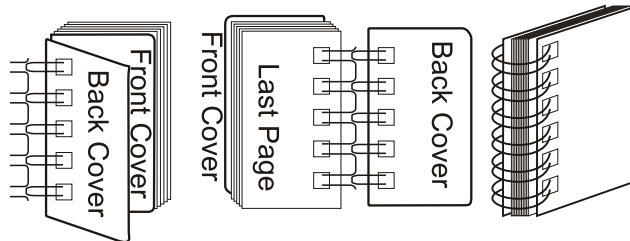

CLOSING

1. If you are closing a large wire (5/8" or larger), and the Wire Closing Plate is not positioned all the way to the top, press the Reset/Return button to move the Wire Closing Plate to the top position.
2. Place the wire (with sheets properly inserted) into the Wire Closer Channel. The open-side of your wire should face the Magnetic Guide, while the narrow loops are on top. The Magnetic Guide will help lock the wire into position during the closing operation.

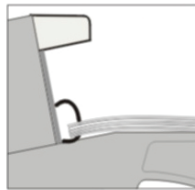

3. Make sure the wire is horizontally-centered in the Wire Closer Channel. Never place wires (especially short wires) on only one side of the machine.



4. Before making the first book, it is recommended that you first take a sample wire and follow the MICRO-ADJUST FEATURE instructions below, to ensure the machine is properly set for your wire.
5. Turn on the power to the machine. The machine will show "HI" or "LO" (See High Efficiency Mode on Page 4). It will then show "31" for 3:1 Wire or "21" for 2:1 Wire. Press the "-" button to change between the two settings. Wires 9/16" & under will need the correct setting to close properly.
6. Press the START button on the control panel to activate the machine. Thanks to its SMART-DETECT system, the Wire Closing Plate will move downward to first detect the wire size, then close the wire automatically.
7. Take out the wire bound book and turn the back cover over. The wire binding is now complete, with the seam inside the back cover.
8. TIP: The seam of a closed wire should have the narrow loops barely touching the wide loops. If this is not the case, use the Micro-Adjust Feature to fine-tune the machine for your particular wire.
9. TIP: When closing wires with smaller diameter sizes, the Wire Closing Plate can be custom set to only return half way after each closure, in preparation for the next operation. This is to save operating time and improve efficiency. See HIGH EFFICIENCY MODE instructions on page 4 for more information.

MICRO-ADJUST FEATURE

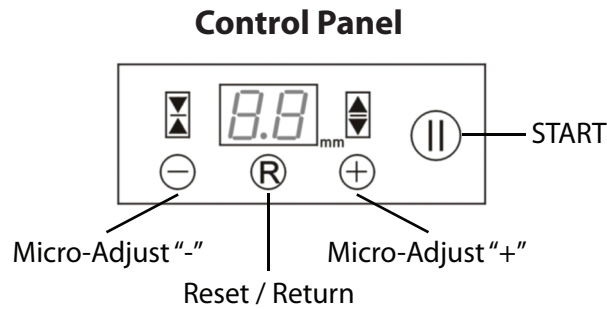

1. Different brands of wires might be produced with different materials and/or different wire forming machines, thus having different flexibilities (wire closing memories). To ensure a perfect wire closing result with all types & brands of wires, your FlexiCloser is equipped with a Micro-Adjust Feature.
2. The Micro-Adjust Feature allows the operator to adjust the closing distance for each wire size independently. To make an adjustment on a particular wire size, the operator should first place such wire by itself (without sheets) into the closing channel, and press START to close it. Then, take out this closed wire and inspect the closing result.
3. If your wire is UNDER-CLOSED (narrow & wide loops not touching each other, pages can fall out), press "-" button on the Control Panel to reduce the closure distance.

The available selection ranges are:

- a. For Smaller Wires (3/16" – 9/16"): 0.3 – 3mm (0.3mm per each adjustment)
- b. For Larger Wires (5/8" – 1-1/2"): 0.6 – 6mm (0.6mm per each adjustment)

Try closing another wire of the same size, and inspect the closing result again. The wire should be properly closed once the correct adjustment has been reached.

4. If your wire is OVER-CLOSED (narrow & wide loops overlapping each other too much, wire is crushed), press "+" button on Control Panel to increase the closure distance.

The available selection ranges are:

- a. For Smaller Wires (3/16" – 9/16"): 0.3 – 3mm (0.3mm per each adjustment)
- b. For Larger Wires (5/8" – 1-1/2"): 0.6 – 6mm (0.6mm per each adjustment)

Try closing another wire of the same size, and inspect the closing result again. The wire should be properly closed once the correct adjustment has been reached.

	Perfect Closure	Under-Closed	Over-Closed
Closed Wire (Top View)			
Closed Wire (Side View)			

5. Memory settings will not be erased even if the main power switch is turned off, or power cable unplugged. Therefore, the operator does not need to re-adjust settings for each job.
6. Master Memory Reset: If the operator wishes to erase all memory settings and bring the closing distance of all wire sizes back to the factory default, simply turn on the machine, and HOLD the R button for 3 seconds. The LCD display will show "CL" and all memory settings will then be erased.
7. Individual Memory Reset: If the operator wishes to erase the memory setting for only one type of wire, simply close that specific wire, and then HOLD the R button for 3 seconds. The LCD display will show "CL" and that specific memory setting will be erased.

HIGH EFFICIENCY MODE

1. When closing smaller wires (3/16" to 9/16"), the Wire Closing Plate can be set to only return half-way after each closure, in preparation for the next operation. This is to save operating time and improve efficiency.
2. To check if High Efficiency Mode is currently ENABLED or DISABLED, simply turn off the machine and then turn it on. Within the first few seconds, the LCD Display will show "LO" (High Efficiency Mode enabled) or "HI" (High Efficiency Mode disabled).
3. To ENABLE High Efficiency Mode:
 - a. Make sure High Efficiency Mode is currently DISABLED (see instructions above).
 - b. Turn off the main power switch.
 - c. Turn on the main power switch.
 - d. Press and hold "+" for 5 seconds, or until the LCD Display shows "LO".
 - e. High Efficiency Mode has been successfully enabled.
4. To DISABLE High Efficiency Mode:
 - a. Make sure High Efficiency Mode is currently ENABLED (see instructions above).
 - b. Turn off the main power switch.
 - c. Turn on the main power switch.
 - d. Press and hold "+" for 5 seconds, or until the LCD Display shows "HI".
 - e. High Efficiency Mode has been successfully disabled.
5. To bring the Wire Closing Plate back to the top position anytime, simply press Reset/Return button on the Control Panel.

SAFETY SENSOR FEATURE

To prevent the operator's fingers from being accidentally injured by the Wire Closer, your FlexiCloser is equipped with a Safety Sensor Feature. During wire closing operation, if your finger accidentally touches closing plate, the closing plate will retract automatically.

WARRANTY POLICY

Your FlexiCloser has a warranty of one year from the date of purchase. In the event of a manufacturer's defect, your distributor (at option) will repair or replace it. **IMPORTANT:** This warranty does not cover damages due to improper use or mistreatment of the unit, including any extraordinary event leading to the damage of the machine, whether it is reversible or not.

If the FlexiCloser is not working properly, first follow the corrective actions above. If the problem persists, please contact your dealer for further instructions. Please have your machine's serial number and the purchase date ready. If the machine must be returned to your distributor, it is your responsibility to properly pack and ship it. Any damage incurred during its transportation is not covered by our warranty policy.