



# LAMIPACKER

## Instruction Manual

---

Models:

# LPP6512 (25")

# LPP1112 (43")

---

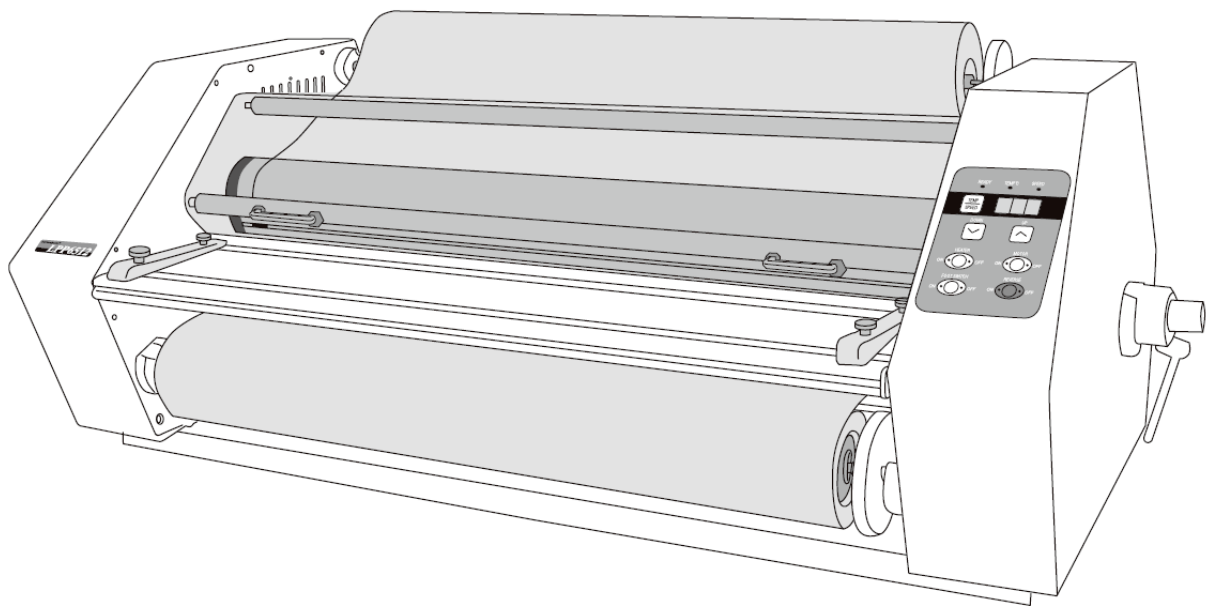

For safe operation, be sure to read through this instruction manual before operating your Laminator.



**DryLam**

**A Trademark of Martin Yale Industries**

251 Wedcor Avenue, Wabash, IN 46992

Brian Jennett- Tech-Line & Service Advisor/Manager

Phone: (260-569-7231)

[www.MartinYale.com](http://www.MartinYale.com)



## Contents

WARNING BEFORE USING YOUR LAMIPACKER .....	3
RECYCLING INFORMATION .....	4
SAFETY PRECAUTIONS.....	5
1. NAMES AND FUNCTIONS.....	6
2. FILM SETTING.....	8
3. WARMING UP .....	10
4. OPERATION .....	10
Stand-by Mode.....	12
5. HOW TO USE REAR CUTTER.....	13
6. FINISHING LAMINATION.....	13
7. CLEANING OF ROLLERS.....	13
8. LAMINATING FILM.....	13
9. SPECIFICATIONS .....	14
10. WARRANTY .....	15

### **DryLam**

#### **A Trademark of Martin Yale Industries**

251 Wedcor Avenue, Wabash, IN 46992  
Brian Jennett- Tech-Line & Service Advisor/Manager  
Phone: (260-569-7231)  
[www.MartinYale.com](http://www.MartinYale.com)

Thank you for your purchase of the Fujipla LPP6512 or LPP1112 laminator with heavy duty roller stand.

This laminating machine is designed to mount and laminate most common foam boards, paper stocks, inks and toners with transparent lamination film. Laminated objects are waterproof and durable as well as having a lustrous appearance.

**NOTE:** While this laminator will perform one-sided lamination, it does not have a de-curling bar. Therefore, upward curl due to film tension may pose a problem with some films and paper stocks, particularly thinner types.

Be sure to read this instruction manual thoroughly before operating your Lamipacker to avoid danger and the possibility of poor quality laminations.

DryLam is a trademark of Martin Yale Industries which is the exclusive distributor of Fujipla products in North America. Contact DryLam's Tech-Line at 260-569-7231 or [brianj@drylam.com](mailto:brianj@drylam.com) with any service related inquiries. Other information is available on our website at [www.MartinYale.com](http://www.MartinYale.com)



## WARNING BEFORE USING YOUR LAMIPACKER



Do not dismantle

Do not open the casing of the Lamipacker or disassemble the machine unless directed by DryLam's Tech-Line.



Warning tangling

If problems (e.g. jamming, etc.) occur, switch off and unplug immediately and then contact DryLam's Tech-Line.



Electric shock

Be careful that your tie, necklace, hair, etc. do not get caught in the machine. In such a case, switch off immediately.



Warning Hot

Do not spill water on the Lamipacker. Do not operate it with wet hands.

Do not set the Lamipacker on the power cord.

Be sure to unplug before moving the Lamipacker.

The surface of Lamipacker and laminated objects may be hot.

Do not laminate prohibited materials (see next item "laminating objects" on page 4).

In the case of incorrect threading/setup, laminating prohibited materials or laminations performed incorrectly smoke may come out of the laminator.

The safety cover should always be placed correctly. Always ventilate the area well when operating. The laminator should be located close to the wall outlet and easily accessible.

### DryLam

#### A Trademark of Martin Yale Industries

251 Wedcor Avenue, Wabash, IN 46992

Brian Jennett- Tech-Line & Service Advisor/Manager

Phone: (260-569-7231)

[www.MartinYale.com](http://www.MartinYale.com)



## RECYCLING INFORMATION

Thank you for choosing this Fujipla product. It is an electronic device containing components which require proper disposal at the end of their effective life. You can help control emerging risks by disposing the electronic device and your domestic waste separately. Electric and electronic devices are marked with a crossed out waste bin indicating that these products should not be dumped together with domestic waste. If being dumped together with domestic waste electric and electronic equipment may have severe impacts on the environment as well as human health the least of which due to the possibly of hazardous materials.

In accordance with the European WEEE directive Fujipla provides an easy way to recycle waste of electric and electronic equipment. Please dispose of electric and electronic equipment waste by using your local collection site for this type of waste.

### **DryLam**

#### **A Trademark of Martin Yale Industries**

251 Wedcor Avenue, Wabash, IN 46992

Brian Jennett- Tech-Line & Service Advisor/Manager

Phone: (260-569-7231)

[www.MartinYale.com](http://www.MartinYale.com)

## SAFETY PRECAUTIONS

For safe operation, be sure to observe following precautions.

### Installation:

1. Do not install the Lamipacker in a humid, dusty area, or near an air conditioner.
2. Install Lamipacker on a level surface and leave enough space in the rear to guide laminated objects out the exit.
3. Do not put anything on top of the Lamipacker.
4. Be certain that the power source connects to a dedicated and grounded AC120V 60 Hz outlet. Do not share the electrical outlet with other devices.
5. Use in a well ventilated room.

### Laminating film:

- While genuine FUJIPLA "CP Roll" is recommended any quality 1.5 or 3 mil laminating film may be used. Contact your dealer.

### Laminating objects:

Lamination is made by heat and pressure. Inappropriate operation may cause failure in quality of lamination or in jamming of film. Avoid lamination of the following:

- Inflammable substances or any substance susceptible to heat (e.g. vinyl chloride, polyethylene, etc.)
- Valuable items which are unique and not replaceable. Do not laminate money.
- Lamination items which exceed 35mil. In total thickness.
- Objects which change color or quality with heat (e.g. thermal paper, pictures drawn with crayon etc.)

### Operation:

- Operate the Lamipacker only for lamination of paper items.
- Do not leave the Lamipacker during operation.

Changes or modifications not expressly approved by the party responsible for compliance could void the user's authority to operate the equipment.

NOTE: This equipment has been tested and found to comply with the limits for a Class B digital device, pursuant to part 15 of the FCC Rules. These limits are designed to provide reasonable protection against harmful interference in a residential installation. This equipment generates, uses and can radiate radio frequency energy and, if not installed and used in accordance with the instructions, may cause harmful interference to radio communications. However, there is no guarantee that interference will not occur in a particular installation. If this equipment does cause harmful interference to radio or television reception, which can be determined by turning the equipment off and on, the user is encouraged to try to correct the interference by one or more of the following measures:

- Reorient or relocate the receiving antenna.
- Increase the separation between the equipment and receiver.
- Connect the equipment into an outlet on a circuit different from that to which the receiver is connected.
- Consult the dealer or an experienced radio/TV technician for help.

### DryLam

#### A Trademark of Martin Yale Industries

251 Wedcor Avenue, Wabash, IN 46992

Brian Jennett- Tech-Line & Service Advisor/Manager

Phone: (260-569-7231)

[www.MartinYale.com](http://www.MartinYale.com)

# 1. NAMES AND FUNCTIONS

## Name of Components

1	Guide Roll
2	Safety Cover
3	Paper Guide
4	Feed Tray
5	Mandrel Holder
6	Heat Roller
7	Mandrel
8	Film Tension Controller
9	Casing (left and right)
10	Operation Panel
11	Lamination Handle
12	Rear Wire Tray
13	Rear Cutter
14	Power Switch
15	Power Cable
16	Mandrel adaptor for 2-1/4 inch paper core
17	Mandrel adaptor for 3 inch paper core
<b>Not shown</b>	Heavy Duty Roller Stand

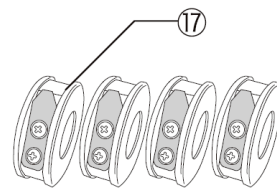
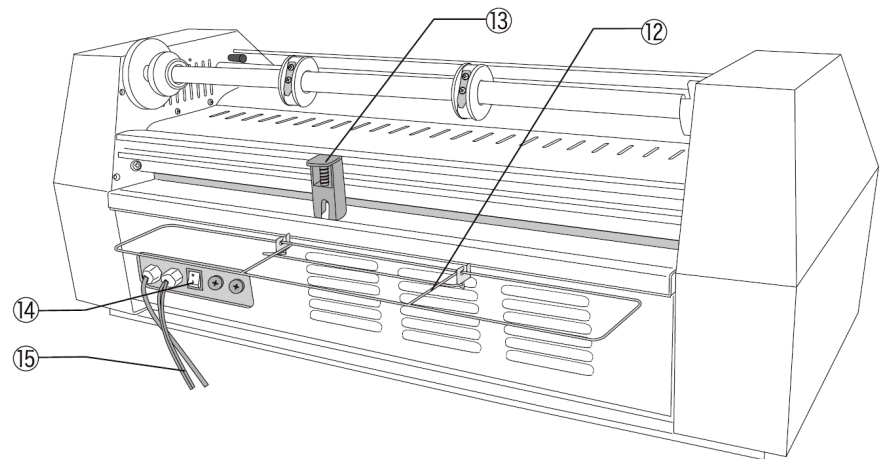
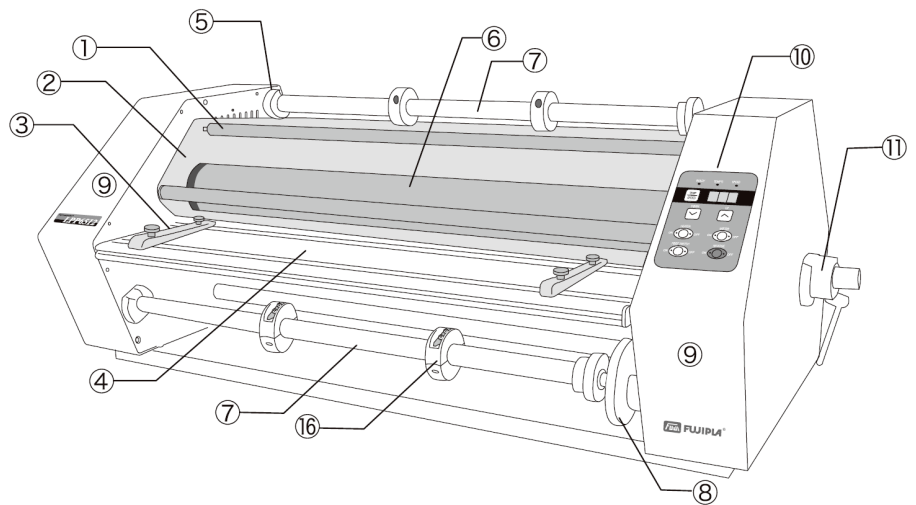

## DryLam

### A Trademark of Martin Yale Industries

251 Wedcor Avenue, Wabash, IN 46992

Brian Jennett- Tech-Line & Service Advisor/Manager

Phone: (260-569-7231)

[www.MartinYale.com](http://www.MartinYale.com)

## Functions

### 1. READY Lamp (yellow)

Yellow lamp glows when the heat roller gets to the desired temperature

### 2. TEMP C Lamp (yellow)

Lamp (yellow) indicates that temperature setting can be adjusted

### 3. SPEED Lamp (yellow)

Lamp (yellow) indicates that speed setting can be adjusted

### 4. TEMP/SPEED Switch

Change display of TEMP/SPEED:

TEMP C lamp: change of temperature is possible

SPEED lamp: change of speed is possible

### 5. DOWN Button

Temperature or Speed can be reduced

### 6. UP Button

Temperature or Speed can be raised

### 7. HEATER Switch

Rubber Roller is heated when this button position is ON (each time you push the button, it will be switched into ON/OFF).

### 8. MOTOR Switch

Motor rotates constantly when this button position is ON (each time you push the button it will be switched into ON/OFF)

### 9. REVERSE Switch

Rollers rotate in reverse

### 10. POWER Switch

Operation on Control Panel is possible when this button position is ON.

### 11. HEATER Fuse

For safety the fuse will blow when HEATER is overloaded

### 12. MOTOR Fuse

For safety the fuse will blow when MOTOR is overloaded

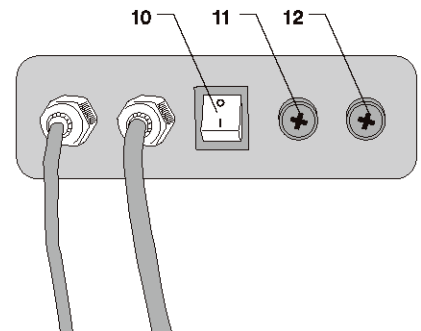
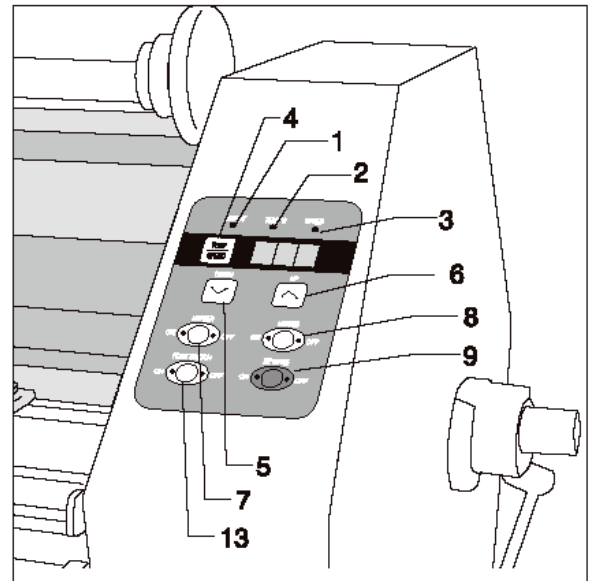

## DryLam

### A Trademark of Martin Yale Industries

251 Wedcor Avenue, Wabash, IN 46992

Brian Jennett- Tech-Line & Service Advisor/Manager

Phone: (260-569-7231)

[www.MartinYale.com](http://www.MartinYale.com)

## Functions (cont'd)

### 13. FOOT SWITCH Button

Operation by foot switch is activated when this button position is ON (each time you push the button, it will be switched into ON/OFF)

## 2. FILM SETTING

1) Remove Safety Guard and Feed Tray in order to set film. (fig.1)

\*To remove Safety Guard, lift the near end, pull it upward and take it out from support pins.

\*To remove Feed Tray lift the near end, pull it toward you, and take it out from support pins.

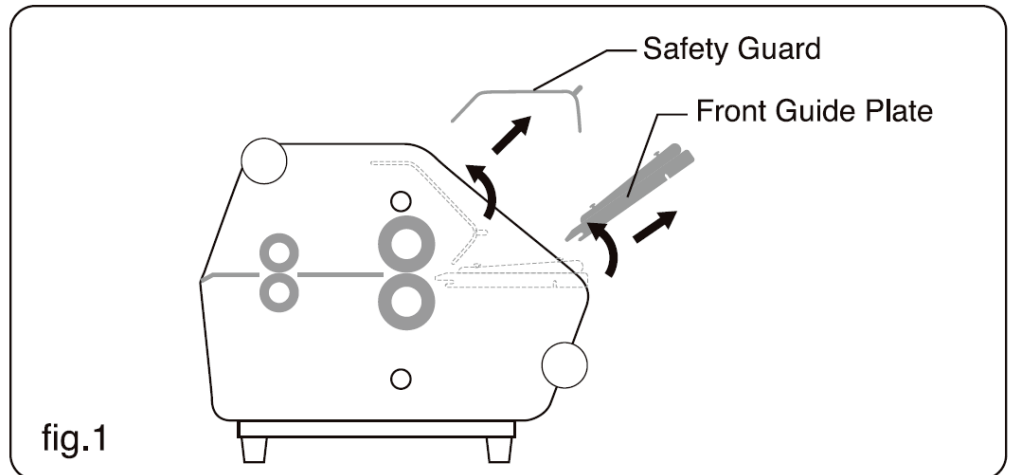

2) Remove the Upper and Lower Mandrels.

## DryLam

### A Trademark of Martin Yale Industries

251 Wedcor Avenue, Wabash, IN 46992

Brian Jennett- Tech-Line & Service Advisor/Manager

Phone: (260-569-7231)

[www.MartinYale.com](http://www.MartinYale.com)



## Film Setting (cont'd)

3) Install the proper mandrel adaptors on the mandrels. Check that the direction of the hooks are pointing in the same direction. (fig.2)

4) Mandrels are preassembled with the mandrel adaptors for a 2-1/4 inch paper core. When you use roll film with a 3 inch paper core, replace the mandrel adaptors accordingly. (fig 3)

(\*LPP6512 also accepts a 1 inch paper core.)

\* The adhesive tape used at the edge of the roll film should be removed before use, otherwise it may stick to rollers of the machine.

5) Insert the Mandrel into the film roll.

**NOTE:** Be sure the direction of the hook is pointed in the reverse direction of the film roll and mandrel rotation. See Fig. 3

Place Upper and Lower Mandrels on the machine. (fig.4)

\* Twisting mandrel slightly in the direction of film rotation will help to shift it within the roll.

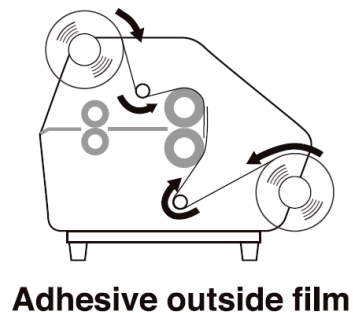
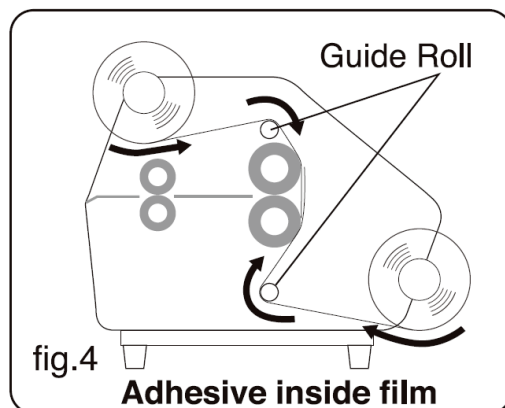
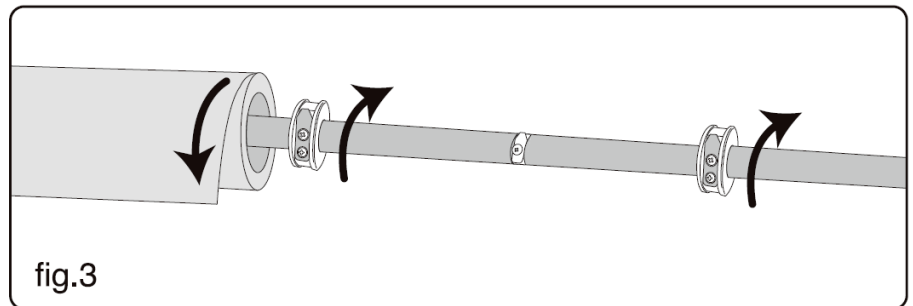
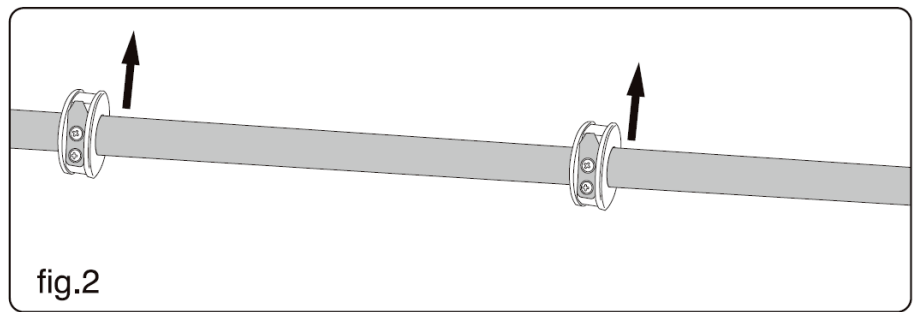

## DryLam

### A Trademark of Martin Yale Industries

251 Wedcor Avenue, Wabash, IN 46992

Brian Jennett- Tech-Line & Service Advisor/Manager

Phone: (260-569-7231)

[www.MartinYale.com](http://www.MartinYale.com)

### 3. WARMING UP

- 1) Plug in the machine and turn on the Power Switch.
- 2) Raise the Lamination Handle and turn on HEATER Switch.
- 3) Set the temperature and speed according to the object to be laminated.
- 4) READY lamp (yellow) will glow in 8 to 30 minutes indicating the machine is ready for use.

### 4. OPERATION

\*Caution: Hot Surface. Caution is required as Heat Rollers heat up.

- 1) Raise the rear exit tray to the operation position.
- 2) Be certain that the position of the Rear Cutter is fully to the left or right end of the rail.
- 3) Pull down the upper film in front of Heat Rollers. Pull the lower film up and overlap the upper film. (fig.5)

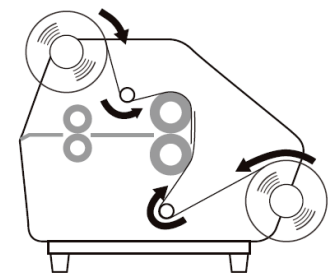
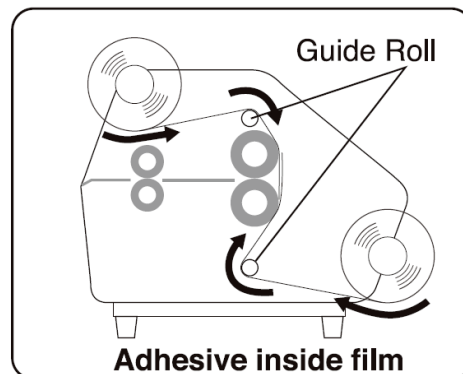

**Adhesive outside film**

- 4) Set Safety Cover and Feed Tray. (fig.6)

\* For safety reasons, the motor does not start unless the Feed Tray and the Safety Cover are installed.

- 5) Using Film Setting Board, push both sheets of film between Heat Rollers.

Then lower the Lamination Handle to lower rubber rollers, set the speed slow and turn on MOTOR Switch to rotate the rubber rollers, paying attention that film doesn't twist around the rollers. The Film Setting Board and film should exit the rear of the laminator.

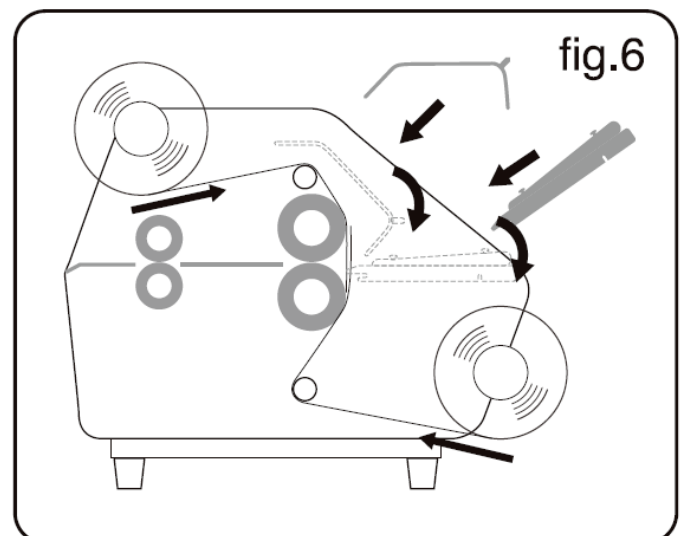

**DryLam**

**A Trademark of Martin Yale Industries**

251 Wedcor Avenue, Wabash, IN 46992

Brian Jennett- Tech-Line & Service Advisor/Manager

Phone: (260-569-7231)

[www.MartinYale.com](http://www.MartinYale.com)

## Operation (cont'd)

### Useful tips

On and off operation of the roller rotation by pushing MOTOR Switch or Foot Switch will help with positioning.

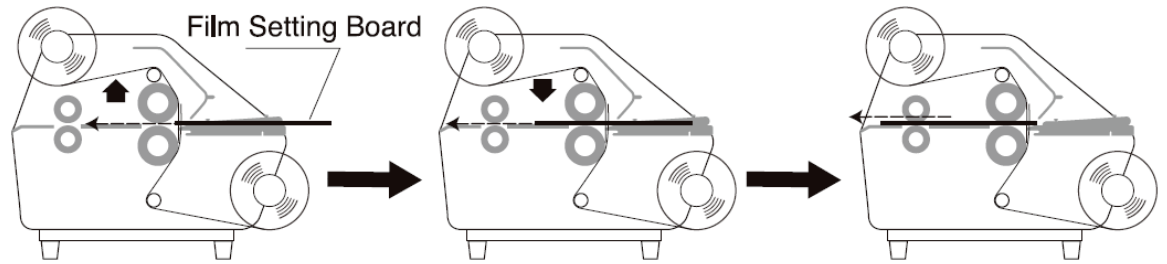

6) Creases (“waterfall”) may appear on the film over the length of the Heat Rollers at the beginning. They will disappear shortly. If they do not disappear, slightly increase the film tension using Tension Controllers on the right sides of the mandrels (rotate them in a clock-wise direction). If both ends of laminated films don't overlap each other properly, adjust the position of the film rolls on the mandrels. If film is not properly overlapped adhesive may get on the rollers.

7) During lamination, be sure that the Feed Tray and the Safety Cover are securely set. The machine will not run without them in place.

### Useful tips: For perfect finish...

1. It is recommended to find the suitable temperature and speed by testing with a similar material before laminating the real object.

2. To get a satisfactory finish, hold the object evenly and straighten/smooth outwards from the center while laminating.

3. If the laminated film is not transparent (cloudy white), the temperature is not high enough. Raise the temperature or reduce the speed to achieve clear lamination.

8) The object being laminated should be placed on the Feed Tray evenly and at a right angle, otherwise a part of the object may come out of the film while processing.

\* In order to place it evenly with the machine, set the width of Paper Guide(s) on the Feed Tray the same as the laminated object.

9) The laminated film will emerge from the pull rollers in the rear of the laminator. At this moment, the temperature of the laminated film is high (approx. 86-104°F).

### Caution:

a) Do not press REVERSE Button except in case of emergency. When it is pressed, all the rollers rotate in the reverse direction.

## DryLam

### A Trademark of Martin Yale Industries

251 Wedcor Avenue, Wabash, IN 46992

Brian Jennett- Tech-Line & Service Advisor/Manager

Phone: (260-569-7231)

[www.MartinYale.com](http://www.MartinYale.com)

## Operation (cont'd)

b) When you want to stop the laminating process, press MOTOR Switch to stop the rollers and lift up the rollers. If the rollers are kept heated and pressured the rubber of the roller may deteriorate.

### Stand-by Mode

After about 30 minutes with settings of HEATER:ON, MOTOR:OFF, the laminator will automatically shift into stand-by mode. Temperature will be dropped to 122°F, the lowest preset temperature. Simply reset the temperature when you resume operation.

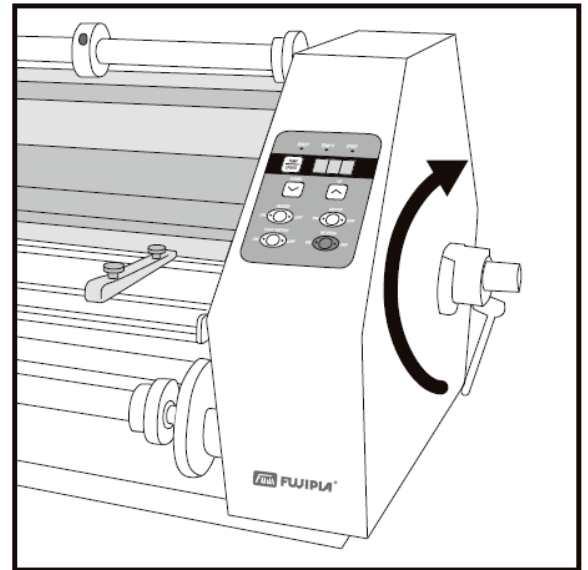

## DryLam

### A Trademark of Martin Yale Industries

251 Wedcor Avenue, Wabash, IN 46992

Brian Jennett- Tech-Line & Service Advisor/Manager

Phone: (260-569-7231)

[www.MartinYale.com](http://www.MartinYale.com)

## 5. HOW TO USE REAR CUTTER

Use the Rear Cutter as follows when you wish to cut film after stopping the rollers.

1) Press down on the top of the cutter, as cutting edge comes out from the body of the cutter. Slide the cutter horizontally to cut the film. (Cutting can be done from either left or right side.)

\* Provide tension to the film while cutting, as it is difficult to cut when film is hot.

2) Pull the top of the cutter up and slide it to either left or right end of the rail.

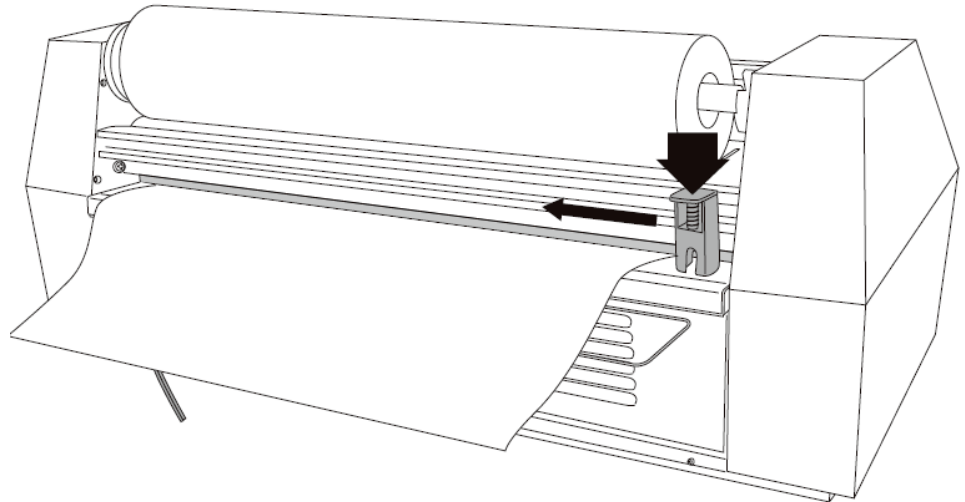

**Caution:** Make sure the cutting edge goes back to the body of the cutter. Otherwise, laminated film will hit the cutter and may cause jamming of film and/or damage of the cutter.

## 6. FINISHING LAMINATION

1) When the lamination is over, turn off HEATER & MOTOR Switches and lift the rubber rollers using Lamination Handle.

\* If the machine is cooled down with the film in position the film may stick to the rollers and the rubber may be damaged when re-started.

2) Take off Safety Guard and Feed Tray.

3) Cut the upper and lower films at the near side of Heat Rollers. Rotate rollers backwards and discharge the film that is left in the machine.

4) Turn off Power Switch, and finish operation after putting Safety Guard and Feed Tray on.

## 7. CLEANING OF ROLLERS

Clean rollers when the operation is over. An excess of adhesive stuck to the rollers may cause film jamming. Fold a sheet of paper {e.g. calendar, catalogue, etc.} in two. Insert it several times between the rollers with folded side ahead. Cleaning periodically by wiping with a rag soaked with methyl or ethyl alcohol is recommended because old adhesive cannot be easily removed. Never use organic solvents (toluene, benzene, thinner, etc.).

Do not use thin paper (e.g. copying paper) for the cleaning of the rollers as it may cause jamming.

**CAUTION:** Do not use metals or sharp materials to remove glue from rollers.

## 8. LAMINATING FILM

It is recommended to use Fujipla or DryLam film. Mismatching of film characteristics to the paper being laminated may cause problems relating to poor film adhesion to paper. Please contact DryLam for further details about laminating films.

**DryLam**

**A Trademark of Martin Yale Industries**

251 Wedcor Avenue, Wabash, IN 46992

Brian Jennett- Tech-Line & Service Advisor/Manager

Phone: (260-569-7231)

[www.MartinYale.com](http://www.MartinYale.com)

## 9. SPECIFICATIONS

<b>MODEL</b>	<b>LPP6512</b>	<b>LPP1112</b>
Maximum Laminating Width	<b>25"</b>	<b>43"</b>
Voltage/Amperage	240VAC/6.7A	240VAC/10A
Power Consumption	1600W	2400W
Laminator Dimension (W x L x H)	40"x19"x16" (+ 29"H for stand)	58"x19"x16" (+ 29"H for stand)
Weight	169 lbs.	196 lbs.
Use Environment /Use Altitude	32 -104°F (68 +- 41F is recommended)/below an altitude of 6562'	
Maximum Laminating Thickness	Up to ¼" foam board	
Laminating Speed	23 - 70"/min (adjustable)	
Temperature Range	Room temperature or 122- 266 °F (adjustable)	
Warm-up Time	Approx. 8 - 30min	
Power Source	AC 240V 60Hz Single Phase	
Plug type	NEMA 6-30P (use 6-30R receptacle)	
Heavy Duty Roller Stand	29" tall, Included	

\*Specifications may be modified without prior notice.

### **DryLam**

#### **A Trademark of Martin Yale Industries**

251 Wedcor Avenue, Wabash, IN 46992

Brian Jennett- Tech-Line & Service Advisor/Manager

Phone: (260-569-7231)

[www.MartinYale.com](http://www.MartinYale.com)

## 10. WARRANTY

This product is manufactured under a strict quality control system and has undergone stringent testing at our factory. To make sure, however, we guarantee the product under the following terms and conditions:

- Should a failure arise under normal operating conditions DryLam will provide the labor to replace any defective part deemed to be due to a manufacturing defect without charge to the original purchaser provided that the product is brought or shipped in to our dealer (at their approval) or to DryLam's Kansas City service center.

We will charge the purchaser for the following cases, even in the warranty period:

- Any breakdown or damage arising from abuse, neglect or any alteration or modification to the machine.
- Any breakdown or damage from fire, earthquake, or any act of God.
- Any charges for shipping and for shipping damage.

This warranty does not cover paper stocks that cannot be laminated satisfactorily. Issues involving adhesion are considered to be compatibility issues and not faults of the laminator.

Any visual changes in cosmetic parts caused by normal use or shipping damage are not covered under warranty.

\*To inquire about maintenance or to order laminating film, please contact your FUJIPLA dealer or DryLam.

THIS WARRANTY IS EXPRESSLY IN LIEU OF ALL OTHER WARRANTIES EXPRESSED OR IMPLIED INCLUDING THE WARRANTIES OF THE MERCHANTABILITY AND FITNESS FOR USE AND OF ALL OTHER OBLIGATIONS OR LIABILITIES ON OUR PART, AND WE NEITHER ASSUME NOR AUTHORIZE ANY OTHER PERSON TO ASSUME FOR US, ANY OTHER LIABILITY IN CONNECTION WITH THE SALE OF THIS MACHINE OR ANY PART THEREOF WHICH HAS BEEN SUBJECT TO ACCIDENT, NEGLIGENCE, ALTERATION, ABUSE OR MISUSE. WE MAKE NO WARRANTY WHATSOEVER IN RESPECT TO ACCESSORIES OR PARTS NOT SUPPLIED BY US.

THE TERM "ORIGINAL PURCHASER" AS USED IN THIS WARRANTY, SHALL BE DEEMED TO MEAN THE PERSON OR COMPANY WHO FIRST PUTS THE EQUIPMENT INTO SERVICE (PURCHASED OR LEASED) AND IS LIMITED TO A PERIOD OF ONE YEAR. THIS WARRANTY SHALL APPLY ONLY WITHIN THE BOUNDARIES OF THE CONTINENTAL UNITED STATES.

(end)



**DryLam**

**A Trademark of Martin Yale Industries**

251 Wedcor Avenue, Wabash, IN 46992

Brian Jennett- Tech-Line & Service Advisor/Manager

Phone: (260-569-7231)

[www.MartinYale.com](http://www.MartinYale.com)