

FORMAX[®]

FD 8254CC
Cross-Cut Deskside Shredder

OPERATOR MANUAL

Proper use, warranty

The FD 8254CC is designed for shredding paper. It can also handle small quantities of staples, credit cards and paper clips.

The shredder has a lifetime limited warranty on the cutting head, and a 1 year warranty on all other parts.

Safety instructions

Classification

Safety notice	Explanation
 WARNING	Failure to observe this warning can lead to serious or fatal injury.
Notice	Failure to observe this instruction can cause damage.



Before using the machine for the first time, read the operating manual, and keep it for later use and to pass on to any subsequent users. Observe all safety instructions.

WARNING

Dangerous for children and others!



The machine may not be used by persons (including children under 14 years of age) with limited physical, sensory or mental capabilities or with a lack of experience and knowledge, unless they are supervised by a responsible person or are instructed by them on the use of the machine. Children must be supervised to ensure they do not play with the machine. Do not leave the document shredder switched on when it is unattended.



WARNING

Risk of injury!

Do not reach into the paper feed slot.



Risk of injury from being pulled in!



Keep long hair, loose articles of clothing, ties, scarves, jewelry, etc. away from feed opening.



Material with the tendency to form loops, e.g. tapes, strapping material, etc. must not be shredded.

Danger of injury by splinters!

Wear protective goggles when destroying CDs and hard credit cards.

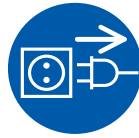

Check the machine and cable regularly for damage. Switch the shredder off if it is damaged or not working correctly or before relocating or cleaning it and disconnect it from the mains.

- Keep the machine, the plug and cable away from open fire and hot surfaces. The ventilation slots must not be blocked or covered and there must be at least 5 cm space between the shredder and any wall or furniture.



Service work which requires the housing covers to be removed may only be carried out by a Formax Service Agency.

Notice Danger from improper use

Only operate this machine in accordance with the instructions outlined in "Proper use".

Machine components

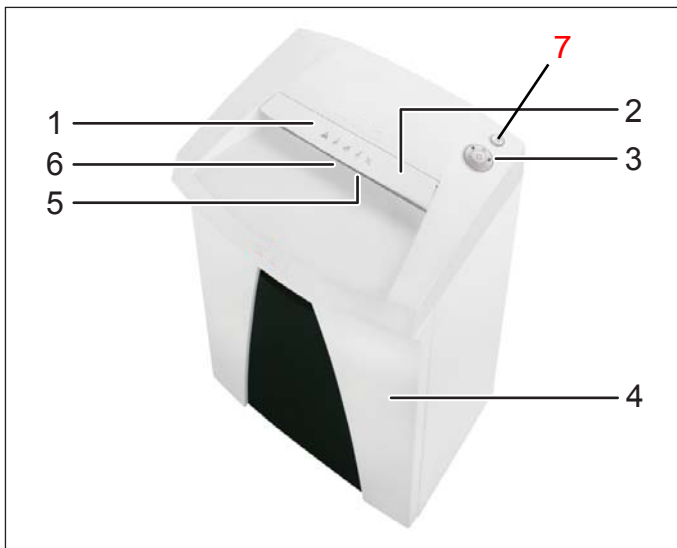

- 1 Safety instructions
- 2 Safety element
- 3 Operating and display unit
- 4 Shredded material container
- 5 Feed opening
- 6 Light barrier
- 7 Reverse button

Operating and display elements

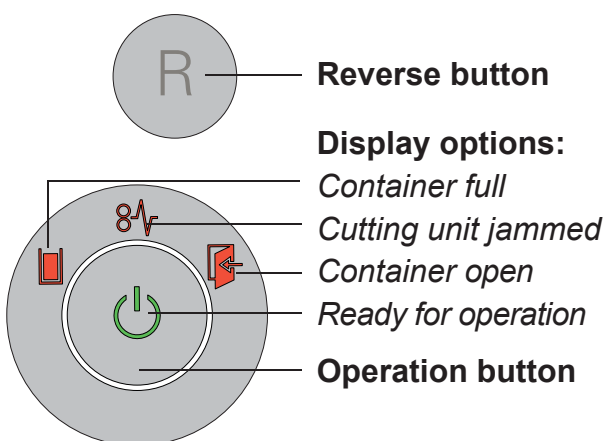

Operation



WARNING

Before switching the machine on, make sure that you observe all safety instructions.

Switching on the shredder

- Connect the power plug of the machine into a properly installed socket.
- Set mains switch at rear of the shredder to "I".
- Press the operation button.
- The "Ready for operation" indicator lights up.

Shredding paper

- When you feed paper, the light sensor automatically starts the cutting unit.
- Two seconds after the light sensor in the paper feed opening is free again, the cutting unit is switched off automatically and the shredder switches to standby.

Shredding credit cards (see "Proper Use")

Insert credit cards in center of the feed opening.

Switching off the shredder

- Press the operation button.
- The "Ready for operation" indicator goes out.
- Set mains switch at rear of paper shredder to "0".

- **7 cbljbc i ci g mode**

Application: Destroying large quantities of paper

Function: Cutting unit runs continuously.

If no material is fed within a period of 2 minutes, the cutting unit shuts down and the shredder switches to standby.

Start: Press the on/off button for at least 4 seconds.

To cancel: Press the on/off button.

- **Automatic shutdown**

Function: If the shredder is not used for one hour, it shuts down completely and therefore does not consume any more electricity (at night, at the weekend).

Restart: Press the operation button.



- **Standby mode**

Function: Two minutes after the last paper feed operation, the shredder is switched off automatically.

The “Ready for operation” indicator goes out briefly at regular intervals.

The shredder starts automatically when paper is fed in.

Troubleshooting

	Paper jam	<p>You have fed in too much paper.</p> <ul style="list-style-type: none"> ➤ The cutting unit runs in reverse for a few seconds and pushes the paper back out again. • If necessary, press the reverse button “R” to remove the stack of paper. • Take half the stack of paper. • Feed the paper in portions. <p>Note: This indicator lamp also lights up when the motor is overloaded. In this case, let the shredder cool down for 20 minutes before using it again.</p>
	Shredded material container full	<ul style="list-style-type: none"> • Empty the shredded material container. <p>Note: If you press the reverse button briefly before removing the container, part of the material is pulled back into the cutting apparatus.</p>
	Container open	<ul style="list-style-type: none"> • Insert the shredded material container correctly in the base cabinet.

Cleaning and maintenance



WARNING

Dangerous mains voltage!

Switch off the shredder and pull out the mains plug.

When cleaning, use only a soft cloth and a mild soap-water solution. However, no water must enter the equipment.



Oil the cutting unit when cutting performance decreases or the device becomes noisy, or every time you empty the waste

container.

Only use FORMAX special lubricating oil for the cutting unit. To do this:

- Spray the special cutting unit oil through the paper feed along the entire width of the cutting shafts.
- Let the cutting unit run in the permanent mode for about 10 seconds without any paper.
- Paper dust and particles are shaken off.

Disposal / Recycling

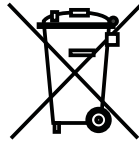

Electrical and electronic old devices contain a variety of valuable materials, but also hazardous substances which were required for function and safety. Incorrect disposal or handling can be dangerous to your health and the environment. Never dispose of old devices in the household waste. Observe the current applicable regulations and use the collection points for returning and recycling electric and electronic devices. Dispose of all the packaging materials as well in an environmentally-responsible way.

Technical Data

Cutting Style:	Cross Cut
Shred Particle Size:	1/8" x 1 1/8"
Shred Capacity:	12 - 14 sheets or 1 credit card
Speed:	Up to 17 feet per minute
Intake Width:	9.4"
Dimensions:	14.8" W x 11.3" D x 23.1" H
Bin Capacity:	8.7 gal.
Weight:	28.6 lbs.
Security Level:	P-4 / Level 3 (HIPAA Compliant)
Power Supply:	110 - 120V, 50Hz

* Sheet capacity varies depending on paper and power supply