

# PUNCH-BIND

## ELECTRIC PUNCHING AND BINDING MACHINE

( from serial number PB.001)

---

---

### OPERATING MANUAL

---

---



**Version 230V**  
**ISSUE 1**  
**January 2003**

SERIAL NO. -----
SHIPPING DATE -----

**T**hank you for buying the **Punch-Bind** electric punching/binding machine from **James Burn International**. This handbook is designed to help you in getting the most from your new punching/binding machine.

**A**lso in the ongoing effort to improve the quality and performance of this punching/binding machine, JAMES BURN INTERNATIONAL reserve the right to make changes. If you need more information about your Punch-Bind machine or this handbook, please contact your dealer or any of the following :

***NOTICE***

**P**lease read this handbook carefully before using your **Punch-Bind**.

---

**T**his handbook contains recommendations and instruction for installing, operating and caring for wire.o® punching/binding machine. Failure to read this material can result in personal injury or damage to your equipment.

***NOTICE***

**T**his handbook is a necessary and permanent part of your punching/binding machine. Always keep this handbook with your machine.

---

**TO NOTE :**

**T**his handbook gives you general guidelines for installing and operating your punching/binding machine. It does not cover every question you may have or every situation that can arise.

If you have any questions about your Punching Machine or this manual, please contact your local James Burn International agent or office shown below :

Your local James Burn International agent or office

- 1. USING YOUR PUNCHING/BINDING MACHINE SAFELY**
  - 1.1 Safety warnings for your punching/binding machine*
  - 1.2 Warning signs on your punching/binding machine*
- 2. INSTALLING YOUR PUNCHING/BINDING MACHINE**
  - 2.1 Lifting the machine*
- 3. GENERAL DESCRIPTION**
- 4. DRIVE INFORMATION FOR PUNCHING SECTION OF YOUR MACHINE**
- 5. INSTALLING/CHANGING A PUNCH TOOL**
- 6. STARTING UP PROCEDURE**
- 7. SETTING UP FOR PUNCHING**
- 8. PUNCHING PROCEDURE**
- 9. UNJAMMING PROCEDURE FOR THE PUNCHING SECTION**
- 10. SELECTION OF WIRE-O<sup>®</sup> SIZE**
- 11. INSERTING THE WIRE-O<sup>®</sup>BINDING ELEMENT**
- 12. CLOSING TOOL ADJUSTMENT**
- 13. CLOSING OF WIRE-O<sup>®</sup> ON YOUR MACHINE**
- 14. REPOSITIONING OF BACK COVER**
- 15. HOW TO EMPTY THE PERFORATION TRAY**
- 16. MAINTAINING YOUR PUNCHING/BINDING MACHINE**
- 17. FAULT FINDING PROCEDURE**
- 18. INFORMATION : PROTECTION GUARD / TABLE**
- 19. SELLING, TRANSFERRING OR DISPOSING OF YOUR PUNCHING/BINDING MACHINE**
  - 19.1 Selling, transferring your punching/binding machine*
  - 19.2 Disposing of your punching/binding machine*

**20. TECHNICAL SPECIFICATIONS**

- 21.1 Machine specifications*
- 21.2 Electrical specifications*

**21. WARRANTY POLICY**

**22. WARRANTY CARD**

**23. DECLARATION OF CONFORMITY**

Learn to recognise safety information and always follow recommended precautions and safe operating practices.

**Here is the Safety-Alert symbol :**

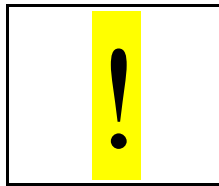

When you see this symbol on your punching / binding machine, or in this handbook, be alert to the potential for personal injury or property damage.

This handbook uses the following words to identify hazards and potential problems.

**TERMS**

**MEANING**

**DANGER**

– It is likely you will cause severe personal injury or death if you ignore this message.

**WARNING**

– You may cause severe personal injury or death if you ignore this message.

**CAUTION**

– You may cause minor personal injuries or substantial damage to equipment or property if you ignore the message.

**NOTICE**

– This is important installation, operation, or maintenance information that you should pay special attention to.



This section lists the safety warnings that you should be familiar with before you try to install or operate your punching/binding machine.

**2**

**DANGER**      **E**lectrical Shock Hazard

**PROTECT CHILDREN**

**K**ee children away from your punching / binding machine.  
Never allow children to operate your punching / binding machine.



**IF YOU NEED THIS HANDBOOK  
IN ANOTHER LANGUAGE**

If you need this handbook in a language other than those published here, contact James Burn International.



**WEAR SAFE CLOTHING**

**S**ecure all loose clothing such as neckties or scarfs when operating your punching/binding machine and keep loose hair tied back.





**KEEP SAFETY LABELS CLEAN AND IN GOOD CONDITION**

Do not remove any safety labels from your punching / binding machine.  
Keep all safety labels clean and in good condition.  
Replace all safety labels missing or damaged.



**KEEP HANDS CLEAR OF THE CLOSING BAR**

Always keep hands clear of closing bar when using binding section to close Wire-O®.



**DO NOT WORK ON THE MACHINE WITHOUT THE SAFETY GUARDS**

When covers are not in place do not work on the machine whilst it is in operation.



Electrical danger



Pinching risk

**BE PREPARED IN CASE OF EMERGENCIES**

Be prepared for fires, injuries or other emergencies.  
Keep a first aid kit and a fire extinguisher handy.  
Keep emergency numbers for Doctors, Ambulance Services, Hospitals and fire Departments handy.  
Accquaint yourself with company fire procedures.



**NOTE TO EMPLOYERS**

**D**o you know your responsibilities as an employer.

- Make sure that all employees know how to operate safely the machine and have read this handbook.
- Make sure your employees are aware of the **safety warnings** on the punching / binding machine and in this handbook.
- Make sure the punching / binding machine is in a proper working condition.

Unauthorised modifications may impair the function and safety of the punching/binding machine.



**HANDLE HEAVY EQUIPMENT PROPERLY**

**A**lways handle heavy equipment with a proper mechanical lifting device. Always locate the weight on your lifting device so that it is stable when lifted or moved. Always check the weight of heavy equipment before attempting to lift it.

Check the maximum rated capacity of your lifting device before using it.

Never try to lift equipment that is heavier than the maximum rating of your lifting device.



**KEEP THIS HANDBOOK WITH THE MACHINE**

This manual is an important part of your punching / binding machine. Always keep this handbook where it belongs on the machine.

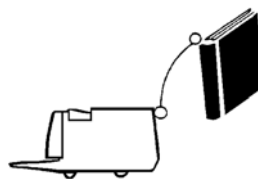

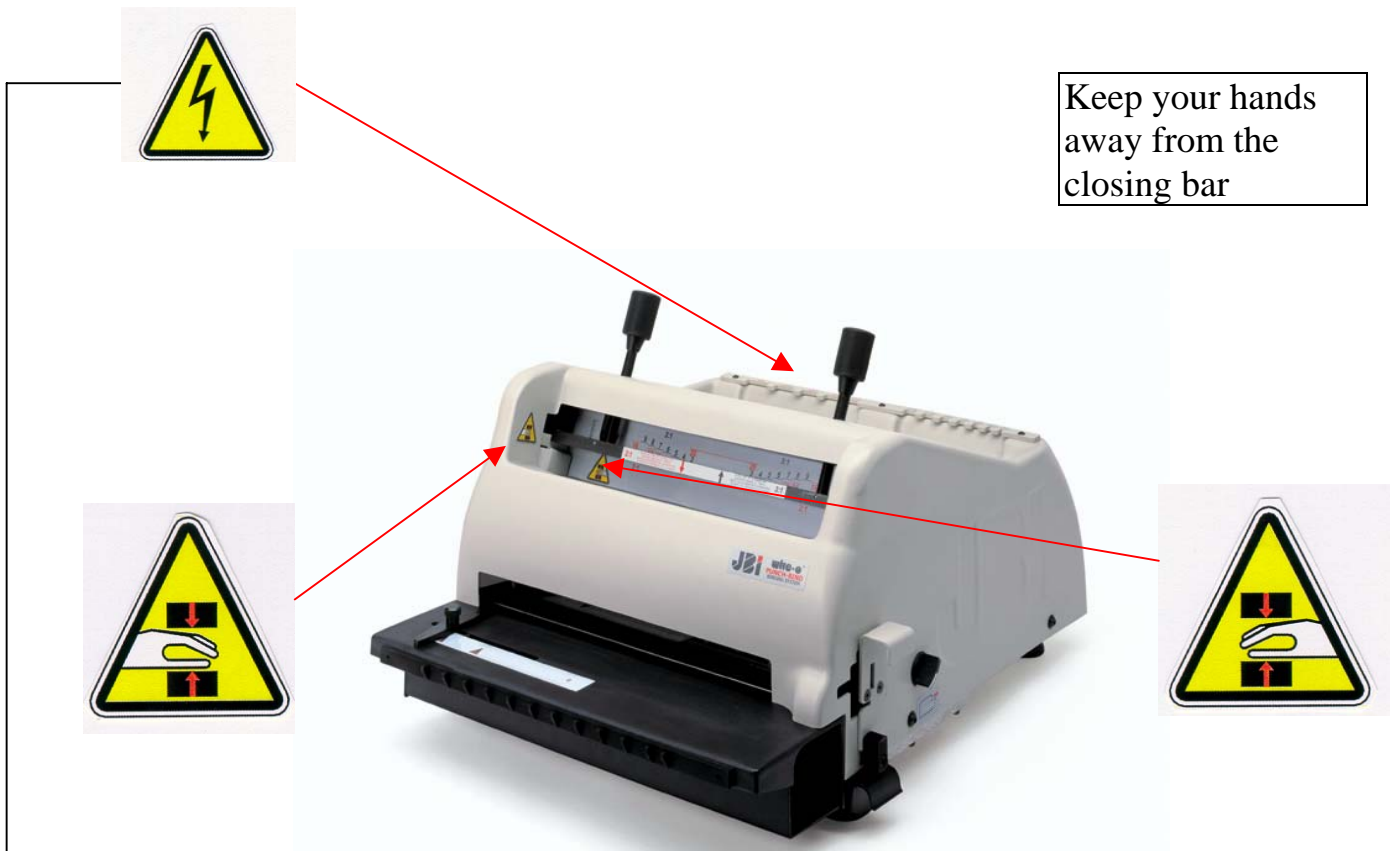

**! WARNING  
DISCONNECT THE  
MAINS SUPPLY  
BEFORE REMOVING  
THIS COVER AND  
WAIT 15 MINUTES  
BEFORE ANY  
OPERATION**

**James Burn International SA**  
67, Rue du Docteur Blaizot, 61304 L'Algle, FRANCE

 a **Standex** company

Marque :	<b>Lhermite</b>	Tension :	<input type="text"/>	V
Modèle :	<input type="text"/>	Intensité :	<input type="text"/>	A
N° de Série :	<input type="text"/>	Fréquence :	<input type="text"/>	Hz
Année de fab. :	<input type="text"/>			

**MADE IN FRANCE** 

Conformity plate at the rear of the machine

**T**he **Punch-Bind** is an office machine. It must be positioned in such a way as to allow access to the perforation tray from the right side of the machine. It will also need clearance behind the machine for adequate ventilation.

Allow about 40cm clearance at the right hand side of the machine so that the punch tool can be easily withdrawn from that machine or the perforation tray can be removed.

Also allow clearance at the left hand side of the machine so that the punched paper can be stacked after punching.

Ensure that a single phase electric connection point is provided nearby : 16 Amp with protection 30mA curve C (with earth, standard C15-100 may 1999).

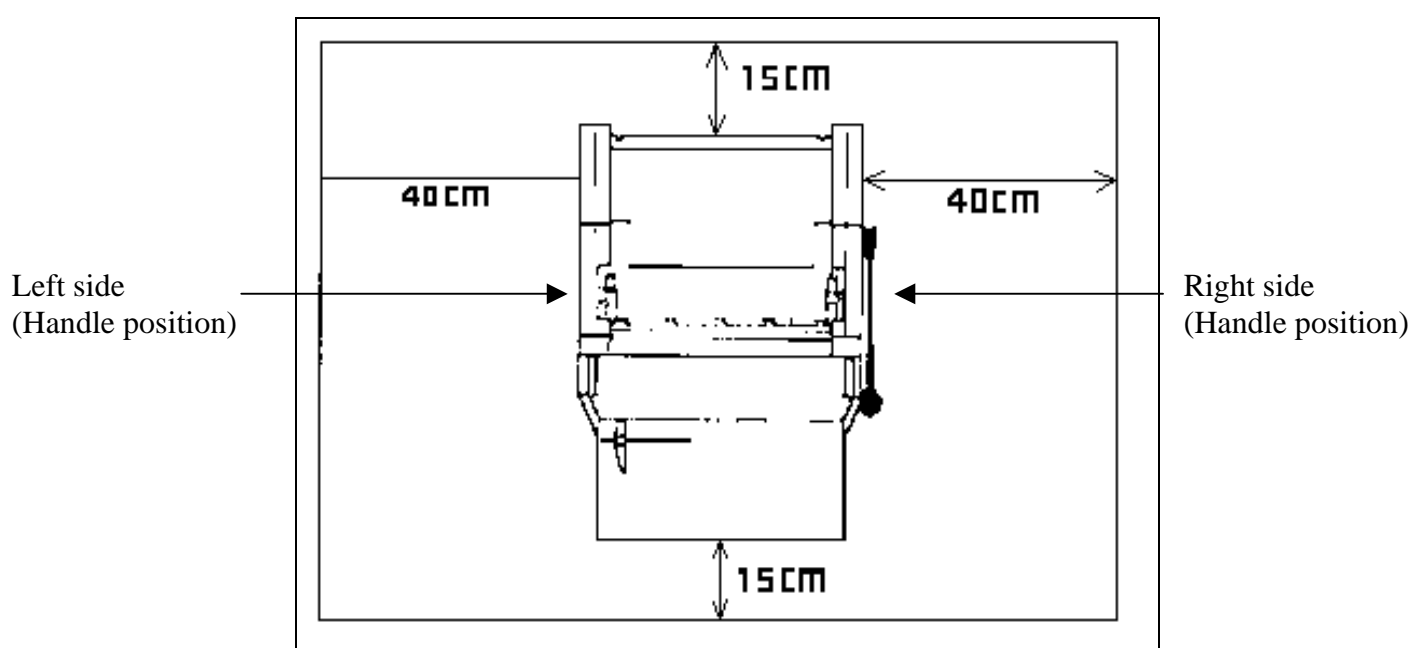

### 2.1 LIFTING THE MACHINE



#### WARNING

1) For personal safety and before lifting the machine, switch off, remove the plug from electric supply.

2) The machine weighs 35 Kg : **Lift the machine with care or ask someone to give you a hand.** It is better that two people lift the machine.

3) Never lift the machine by the front end of the table. The machine must be lifted by the two sides (see above drawing). Always remove the perforation tray before lifting the machine.

**E**lectrically operated punching. Punches up to **2 mm or 25 sheets of 80gsm paper, in using the full width, that is to say 330mm.**

Binds Wire-O<sup>®</sup> from **N° 3 to N° 20 (3/16" to 1" 1/4)**

The machine may be plugged into any earthed single phased socket 16A (protection C 30mA).

**CAUTION : We disclaim liability if you punch only acetate sheets.**

**The machine is started** by switching on the **circuit breaker « 0-1 » by positioning it onto « 1 »** (circuit breaker located at the rear of the machine). When the machine is switched off « 0 », the red light located on the right side of the closing bar is not illuminated.

The machine is now set up correctly. Depressing the foot pedal will operate only one perforation cycle. This is to ensure that there is no double punching.

The machine can be equipped with a range of punching tools for Wire-O<sup>®</sup>, plastic comb, spiral, and other binding systems. Further information is available on request.

The changeover of the tools requires no more than 2 minutes.

The sound level when operating amounts to : **72 dBa from 1 metre of the source.**

A tray is provided to collect confettis when punching, it is fitted underneath the punch tool (introduction from right side).

#### **4. DRIVE INFORMATION FOR PUNCHING SECTION OF YOUR MACHINE 12**

---

**T**he machine is driven by a three-phase motor (P : 0.25 Kw), controlled by an inverter with vectorial flow control which controls the up and down movement of the punch tool. The up and down movement is carried out by an eccentric, which via a connecting rod and yoke enables the punch pins to move up and down.

NOTICE : The stop is always priority with regard to the start.

In case of prolonged jam, the machine will be automatically be switched off by the action of the inverter control, integrating a thermic protection for the motor and the inverter.

NOTICE : The LED located on the right side of the closing bar will not be lit. To cancel this action, switch off the machine and wait 30 seconds before switching the machine on again.

- 5.1 Set the rocker switch in the backward position.  
Press the foot pedal twice to allow the tool to go to its low position
- 5.2 Release the tool by turning the fixing pin anticlockwise.
- 5.3 Pull the tool by its handle slowly to remove it from the machine, placing your hand underneath to support it.  
Engage the new tool making sure that the tool bed plate chamfers are correctly positioned in the lateral guiding rails and push it slowly until the tool stops (tool handle level with the cover).  
Turn the locking pin clockwise.

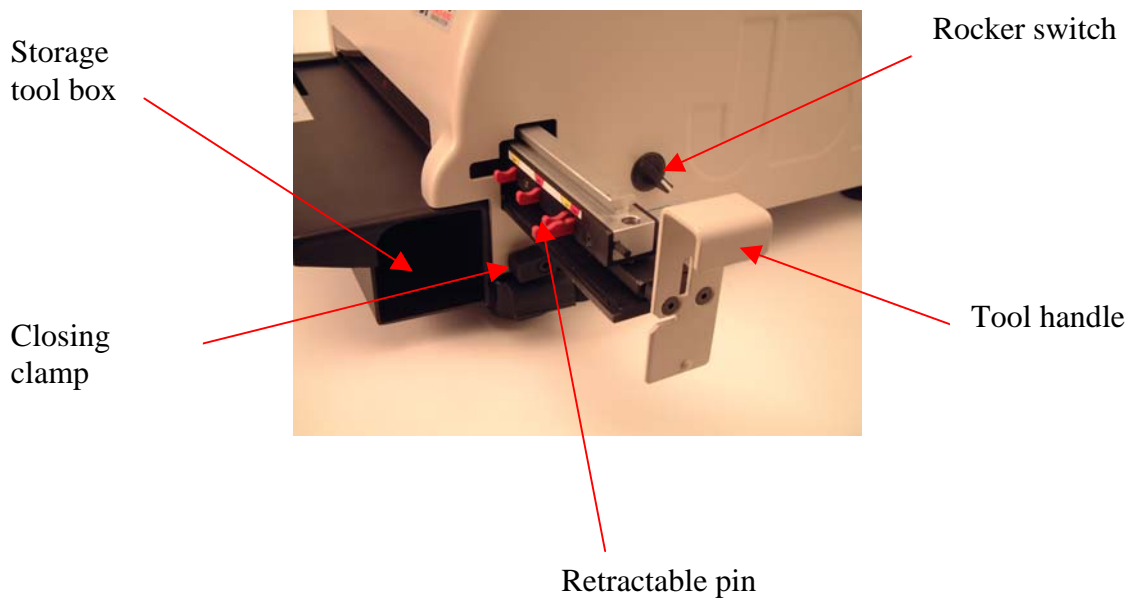

- 5.4 Set the rocker switch to the forward position and press the foot pedal once to put the tool in its high position ready to punch.

**NB** : before engaging the new tool, make sure that pins overlapping the sheet edges are in a retractable position (retractable pins pulled towards the operator, see picture page 13).

**5.5.1.** : for punching 11" sheet with 3/1" pitch, you need to retract one pin at each side of the sheet to be perforated (pin n°7 and 34 marked in red).

**5.5.2.** : for punching 8<sup>1/2</sup>" sheet with 3/1" pitch, you need to retract one pin at each side of the sheet to be perforated (pin n°13 and 28 marked in yellow).

**5.5.3.** : for punching A5 sheet with 2/1" pitch, you need to retract one pin at each side of the sheet to be perforated (pin n°10 and 18 marked in red).

**5.6** Ensure the tool is in full lock so as to be able to clamp it by turning the locking pin clockwise.

**NOTE** :

To make the pin active again, the machine must be in the working position (tool up)

Unlock the closing clamp and remove the tool by the right side of the machine to reach the retractable pins.

A mechanical catch stops the tool inside the machine.



- 6.1** Connect the plug of your machine to mains power supply.
- 6.2** At the back of the machine, press on the circuit breaker « 1-0 » the LED (see picture page 16) located on the right side of the closing bar will light up. The circuit breaker is then in position « 1 ».
- 6.3** The LED doesn't light up :
- Check if your mains power is switched on
  - Check if the circuit breaker protecting your plug is engaged (distribution switchboard)
  - Check the two fuses (on circuit breaker « 1-0 »).

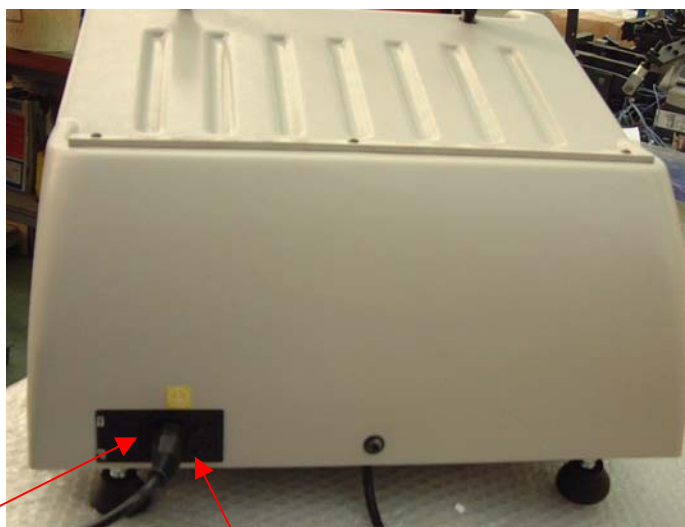

Circuit breaker

Main plug

7.1 Start up the machine as in Section 6.  
**STARTING UP PROCEDURE**

7.2 Place a sample sheet of paper fully into the punching slot so that it contacts the back of the slot squarely.



**-IMPORTANT :**

Always centre the punching area in the middle of the tool to avoid having an irregular pressure and a premature wear both of the tool and the machine.

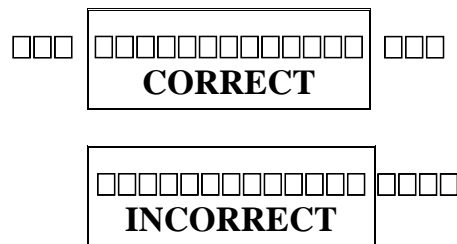

7.3 Align the sheet so that the holes will be centrally positioned on the sheet, by using the graduation on the table.

7.4 Slide lay gauge (**rep.D**) by loosening the knurled knob until it contacts the sheet. Then retighten the knurled knob.

7.5 Remove the sheet, fold it in half and check punched holes are aligned with each other. If not, make minor adjustments to the lay gauge and repeat above procedure.



Laygauge

LED

The number of SHEETS that can be punched in one bite will vary according to the type of paper being used. This will normally be a maximum of 25 sheets of 80gsm paper according to tool version (about 2 to 2.5 mm). The method of punching is as follows :

*See NOTE* for acetate paper

- 8.1 Place a pile of work face downwards neatly at one side of the unit, with the binding edge away from you.
- 8.2 Take approximately 20 sheets (2 mm) turn sheets text upwards, locate sheets squarely against the back of the punching slot and locate against lay gauge.
- 8.3 Operate the foot switch to punch sheets.

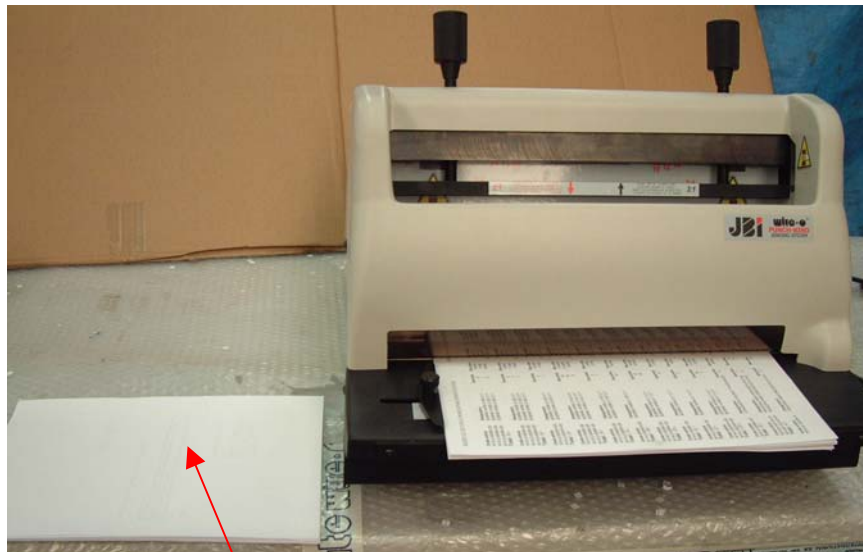

Paper ready to be punched

**NOTE 1**

Ensure that the printed text is returned to its original collated order after punching. The covers are added to the contents at the WIRE-O® inserting stage.

**NOTE 2**

When covers are larger than the contents these should be punched separately and the lay gauge adjusted accordingly.

**NOTICE**

**Do not attempt to punch an excessive bulk of paper**, nor use hard material as this will shorten the life of the machine, create unnecessary jams or reduce the quality of punching.

**9.1** If the machine jams, set the rocker switch in the backward position and press the foot pedal once to allow the tool to come back to its high position.

NOTE : this operation allows disengaging pins from the sheets and then to remove these sheets.



Rocker switch



**CAUTION**

**9.2** If the motor cuts out due to overload, then switch on again after 30 seconds and repeat the operation until the punch tool returns to its up position.

NOTE : do not repeat the operation more than 5 times, then call the after sales service.

**9.4** Reset the rocker switch to forward position to return to operating mode.

**! NOTICE**

**If a mechanical failure involves a jam of the machine, then it will be necessary to call the After Sales department.**

—

The selection of a correct size of WIRE-O® binding is important, in order to obtain a neat presentation and a professionally finished book. A **measuring gauge (capacity selector)** is provided at the rear of the paper tray to determine the correct size number.

**10.1** Holding the complete book together with covers, determine which slot matches the thickness of the book by sliding the book into the correct upright gap of the capacity selector. It should be a secure fit, but not forced.

**10.2** Read the correct Wire-O® size number.

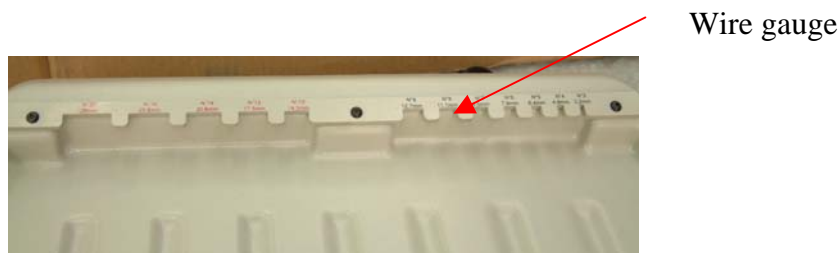

**10.3** 3:1 wire selection chart

Wire-O ® Size no.	Book Thickness		Max. Sheets 80gsm paper (excl.covers)
	Ins	Mm	
3	1/8	3.2	30
4	3/16	4.8	45
5	¼	6.4	60
6	5/16	7.9	75
7	3/8	9.5	85
8	7/16	11.1	100
9	1/2	12.7	120

**10.4** 2:1 wire selection chart

Wire-O ® Size no.	Book Thickness		Max. Sheets 80gsm paper (excl.covers)
	Ins	mm	
10	9/16	14.3	135
12	11/16	17.5	165
14	13/16	20.6	180
16	15/16	23.8	200
20	1"1/9	28.0	250

Prior to inserting WIRE-O® element, arrange the book so that it is face down in the following order, back cover at the bottom followed by the front cover and then the contents.

**To insert WIRE-O® proceed as follows :**

**13.1** Ensure holes are aligned by tapping the punched edge.

**13.2** Place the book face down with the punched holes overhanging the desk edge by about 25mm (1 inch).

**13.3** At one end of the book insert a few loops of the WIRE-O® downwards into the punched holes.



**13.4** Whilst holding the first few loops, stroke the remaining loops of WIRE-O® with the other hand so that they drop easily into all the holes of the sheets.



**13.5** To complete the insertion, twist both ends by 90° so that the open part of the WIRE-O® faces you. The book is then ready for transfer to the closing section.



## ! NOTICE

Prior to closing the Wire-O® element into the book, complete the following procedure :

### 15.1 ADJUSTMENT OF THE CLOSING TOOL

The adjustment is carried out by using the **2 adjustment screws** to move down and up the **closing bar**. **Both adjustment screws must be actioned in parallel. Do not use any tool to loosen the 2 screws. The loosening has to be achieved manually only.** This allows to check if there is no hard point.

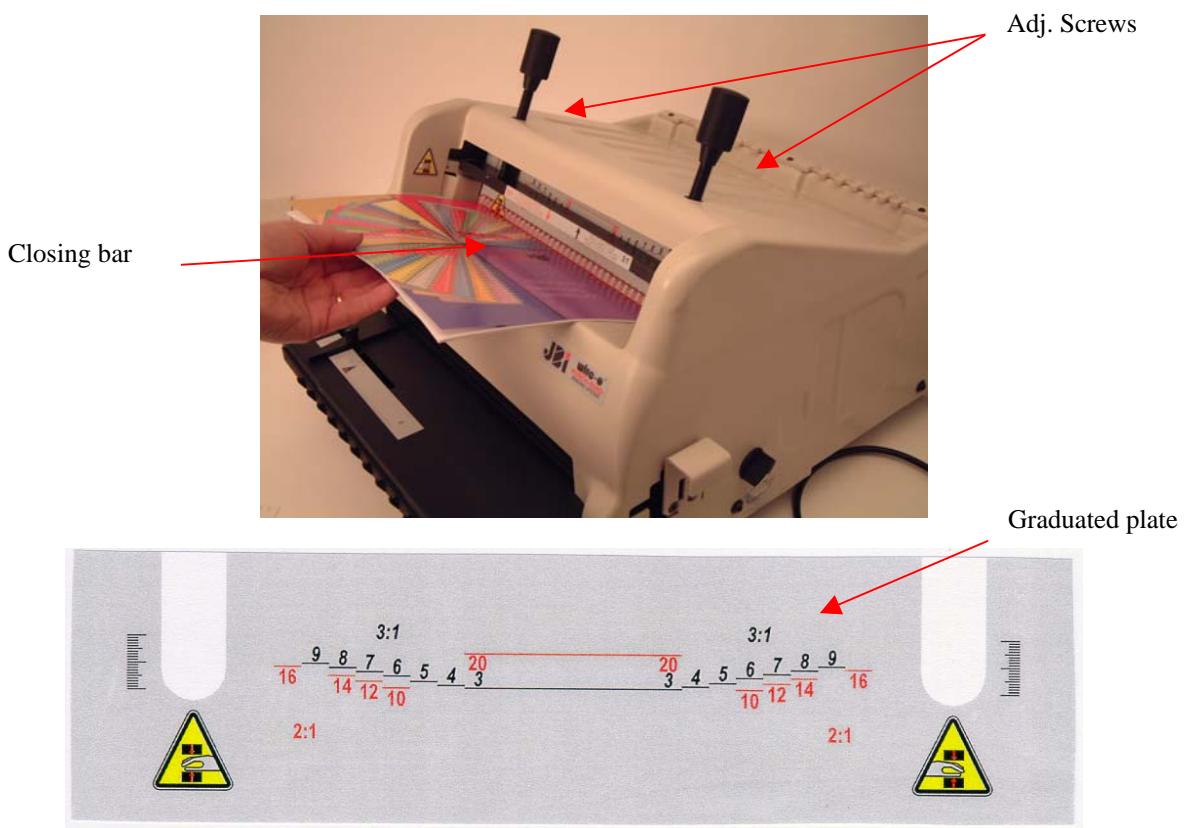

Adjust the height with both adjustment screws by referring to the graduated plate and number of Wire-O® you wish to use.

Make a trial with the chosen Wire-O® and adjust accordingly, if necessary, by achieving the previous operations again.

In 3/1 pitch the size markers are in black and above the bar

In 2/1 pitch the size markers are in red and below the bar

The positioning of the closing bar is carried out by superposing the corresponding points of reference on the graduated plate with lines of the fixed area (it gives an approximate measurement).

**IMPORTANT : the non-compliance with this procedure will involve the cancellation of the warranty of the machine.**



**12.1 SAFETY WARNINGS DURING THE CLOSING TOOL**

4 never push objects in the closing jaws. It may cause damage.

4 never forget to switch the machine OFF and remove power cable before taking care of the closing jaws.

4 2 sensors placed underneath the closing bar lock the machine and cut the power supply of the motor if they are occulted.

**13.1** With one hand, place a book with its inserted WIRE-O® into the binding section of the unit (between the fixed side and adjustable closing bar so that the open ends of the WIRE-O® element are resting squarely on the platform).

**13.2** Lightly press the book down so that it stays in position.

**13.3** Press the foot pedal to achieve a cycle.



**13.4** If the machine jams, set the rocker switch in the backward position and press the foot pedal once to allow the closing bar to come back to its high position.

**13.5** Withdraw the bound book and check that the WIRE-O® has been closed correctly, ie when the narrow loop just enters the space between the adjacent broad loops, so that neither the cover nor sheets can drop out.

**13.6** Should the WIRE-O® be over or underclosed, then simply reset the adjusting gauges to compensate accordingly.

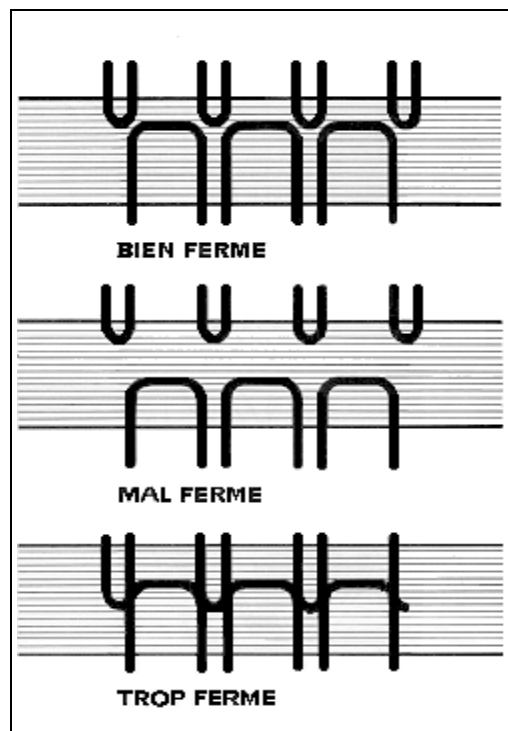

Good close

Bad close

Over closed

**13.7** The adjustable closing bar is supplied with a little press to maintain the sheets. If you do not use the right size of Wire-O® (diameter too small for the width of the book), the closing bar will not operate.

*17.1* Hold the book.

*17.2* Turn the back cover around the WIRE-O® binding.

*17.3* Lay the book flat to complete the operation.

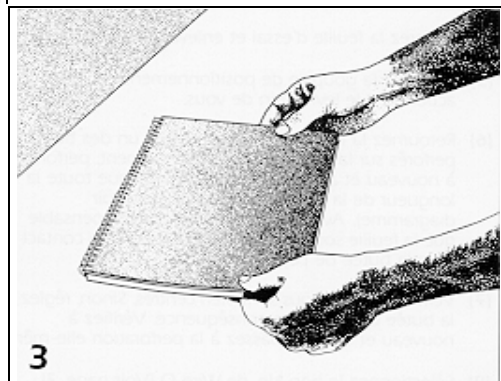
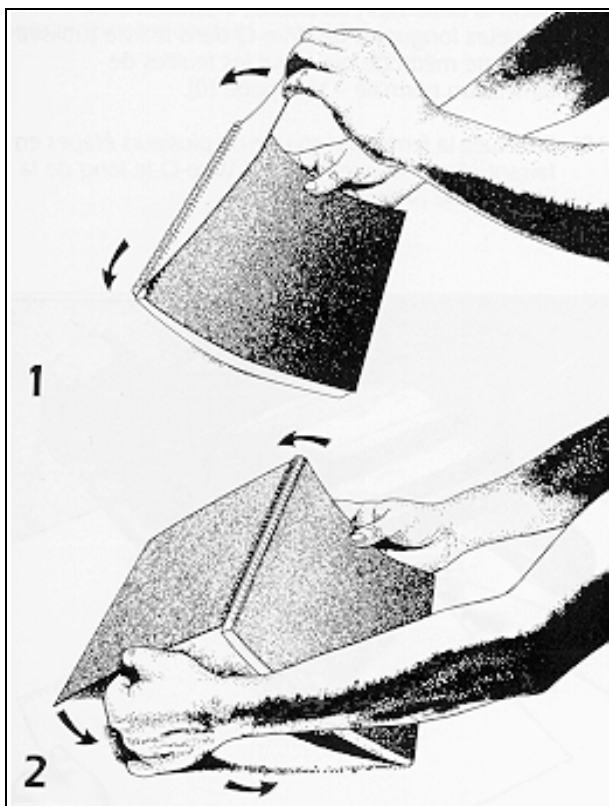

**! NOTICE**

The perforation tray slides out from underneath the table. It holds confettis (paper punching) which are created when punching and must be emptied regularly.

- 18.1 Pull out the confetti tray by the handle (by the right side).
- 18.2 Empty the confetti tray.
- 18.3 Slide the confetti tray laterally at the level of the tool until it is no longer visible.



Confetti tray

**NOTICE**

This is an important section and any lubrication recommended in Section 16.1 on GENERAL MAINTENANCE can be applied by any user of this machine providing they follow the procedure and only use the recommended lubricants. Use of the wrong lubricants may damage your punch tool.

**16.1 GENERAL MAINTENANCE**

Maintenance of your punching machine is limited to the punch tool.

**WARNING**

Before beginning with the maintenance work, switch off the machine, remove plug from electric supply for personal safety.

***THE FOLLOWING DAILY MAINTENANCE IS ADVISED ONLY IN CASE OF CONTINUOUS USE***

***THE FOLLOWING WEEKLY MAINTENANCE IS NECESSARY***

Lightly lubricate punch pins with a paraffined sheet or with pure oil as **KLINGERFLON SPRAY (P.T.F.E.)** or equivalent

It is recommended to punch a few test sheets to ensure that any surplus lubricant on the punch pins has cleared itself and it is not marking the paper.

**NOTE** : If you use a sheet with a lubricant, fold in the sheet in two parts (to contain the lubricant) then punch the sheet.

**16.2 TRANSPORTING**

Care should be taken when transporting so that no damage occurs to the cable from the foot pedal as it could cause bad running, but without any risk for the operator.

**WARNING**

**For replacement of circuit board, please contact the after-sales department**

<b>Nbr</b>	<b>SYMPTOM</b>	<b>POSSIBLE CAUSES</b>	<b>ACTION</b>
<b>1</b>	<i>Machine will not operate when switched on (the sensor on right side is off)</i>	<b>a)</b> No power <b>b)</b> Power fuse blown or no fuse <b>c)</b> Inverter blocked jam <b>d)</b> Electric breakdown	<b>a)</b> Check mains plug is well connected <b>b)</b> Check the 2 fuses on circuit breaker <b>c)</b> Disconnect the machine wait 30 seconds then reconnect the machine <b>d)</b> Contact the after sales department
<b>2</b>	<i>With machine switched on, no reaction on depression the foot pedal (the sensor on right side is on)</i>	<b>a)</b> Tool incorrectly positioned or not locked <b>b)</b> Interruption of the cable from pedal <b>c)</b> Sensors unlined <b>d)</b> Sensors occulted	<b>a)</b> Check tool position and clamping. <b>b)</b> Check that the cable of the pedal is not cut or damaged <b>c)</b> Contact the after sales department <b>d)</b> Remove the object and clean the 2 sensors
<b>3</b>	<i>The machine switches off itself during operation (the right sensor is off)</i>	<b>a)</b> Punch tool jammed. <b>b)</b> Drive linkage seized	<b>a)</b> See fault 4 below on punch tool jamming. <b>b)</b> Contact the after sales department.
<b>4</b>	<i>The punch tool jams</i>	<b>a)</b> Paper too hard or too much sheets. <b>b)</b> Mechanical failure <b>c)</b> Fixing of the tool uncorrect.	<b>a)</b> Operate unjamming procedure (cf. page 20) <b>b)</b> Contact after sales service <b>c)</b> Check position and clamping of the tool.
<b>5</b>	<i>Punch tool runs on at end of stroke</i>	<b>a)</b> The contact of the foot pedal is not correct.	<b>a)</b> Contact the after sales department

**NOTICE****Do not remove from the machine :**

- 1**    *The table*
- 2**    *The tool guard*
- 3**    *The machine housing*

These parts are set by the manufacturer. If, for any reason it becomes necessary to remove any of the above items, then contact the after sales department.

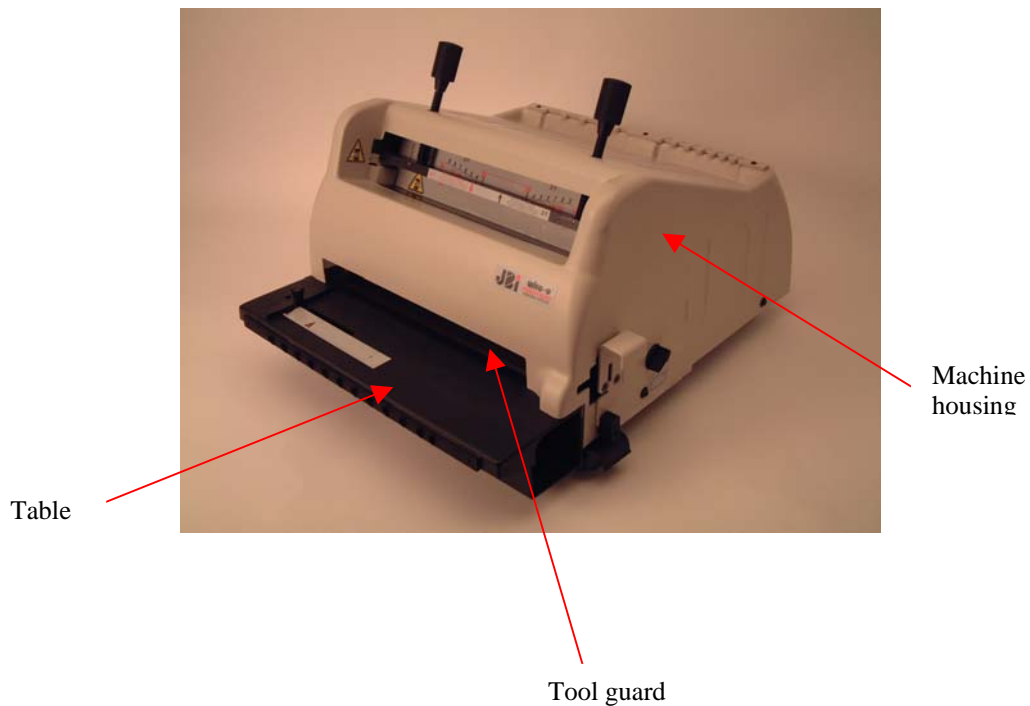

**19.1 SELLING OR TRANSFERRING YOUR MACHINE**



**NOTICE**

*If you sell or transfer your machine, you must ensure the machine is in working order, the labels and this handbook are included and are in readable condition. Failure to do so could result in your being made responsible if the person to whom you sell or transfer your machine gets hurt using it.*

**19.2 DISPOSING OF YOUR MACHINE**



**NOTICE**

*If you dispose of your machine, you must destroy it before you throw it away.*

**To destroy your machine, follow the instructions hereunder :**

- 1.** Remove the punch tool
- 2.** Remove the electric module
- 3.** Remove the confetti tray
- 4.** Cut the link cable
- 5.** Cut the cable of the pedal close to the cover end
- 6.** Throw the punch tool, the electric module, confetti tray, power cable and foot pedal away in separate location to the rest of the machine.



**20.1 MACHINE SPECIFICATION**

<b>WIDTH</b>	<b>410 mm</b>
<b>HEIGHT</b>	<b>340 mm</b>
<b>DEPTH</b>	<b>800 mm</b>
<b>NET WEIGHT</b>	<b>35 Kg</b>
<b>GROSS WEIGHT</b>	<b>49 Kg including packaging box</b>

**21.2 ELECTRICAL SPECIFICATION****CAUTION**

***This is not a dual voltage machine. Operate machine only to the supply voltage shown on the machine nameplate located at the rear.***

**SUPPLY**

220/240 V singlephase 50 Hz Europe version  
or  
110/120 V singlephase 60 Hz US version

**Power required is : 0,4 KW (for 50 Hz or 60 Hz )**

**PLEASE NOTE**

The machine is also protected by 2 fuses located on the circuit breaker « 1-0 » at the rear of the machine :

Fuses bore : 2 fuses T6.3A Europe version 230V singlephase 50Hz  
2 fuses T10 A US version 110V singlephase 60 Hz

**Do not detach the warranty card**

**JAMES BURN WARRANTY**

***This warranty is restricted to the provision of labour (including travel costs) and the replacement of parts and components as defined below, which are found to have been faulty at the time of manufacture or caused by the negligence of James Burn International. It expressly excludes claims due to misuse or bad handling by employees of the customer or third parties.***

***The period of warranty for equipment supplied by James Burn International (JBI) is twelve months for mechanical parts, labour and travel costs and six months for electrical components from the date of delivery to the customer's address.***

***Consumable parts are excluded from the warranty.***

***JBI reserves the right to request the return of any faulty part or component before a replacement is sent out on a free of charge basis. Where this is impractical or the component has not yet been returned, JBI will charge for the component upon despatch and credit the customer upon receipt of the returned faulty part.***



67, Rue du Docteur Blaizot

B.P. 134

61304 L'AIGLE Cedex

Phone : 02.33.84.21.50

Fax : 02.33.84.21.51

**Réf. : Punch-Bind Issue 1**

*Please retain this top part for your information. Should you however require service under the terms of our warranty, please return this card with a brief description of the problem on the reverse side and set it to address below. A charge will be raised for repairs carried out after the expiry of the warranty period.*

<b>SERVICE REQUEST CARD</b> <b>ELECTRIC PUNCHING/BINDING MACHINE PUNCH-BIND</b>
--

*Date of purchase* : .....

*Dealer's name and address* : .....

.....

*Date registration card sent to James Burn International* : .....

*Machine serial number* : .....

**James Burn International**  
 67, Rue du Docteur Blaizot  
 BP 134  
 61304 L'Aigle Cedex  
 Phone : 02 33 84 21 50  
 Fax : 02 33 84 21 51

✕.....

**Réf. : Punch-Bind issue 1**

<b>REGISTRATION CARD</b>
--------------------------

**PLEASE FILL IN AND RETURN THIS CARD TO THE RELEVANT JBI ADDRESS**  
*(see back cover of this handbook)*

*Company name* : .....

*Address* : .....

*Phone* : .....

*Type of business* : .....

*Dealer's name and address* : .....

.....

*Date of purchase* : .....

*Machine serial n°* : .....

*What made you aware of the wire.o® punching/binding machine PUNCH-BIND ?*

*Exhibition*    
  *Advertisement*    
  *Other user*

*Your name : (Mr/Mrs/Miss)* : .....

*Title* : .....

*Signature* : .....



**EC MACHINERY DIRECTIVE  
DECLARATION OF CONFORMITY**

NAME OF THE MANUFACTURER OR SUPPLIER : *JAMES BURN INTERNATIONAL SA*

FULL POSTAL ADDRESS : *67 rue du Docteur Blazot BP 134*

POSTCODE : *61304 L'AIGLE CEDEX*

COUNTRY : *FRANCE*

NAME, TYPE OR MODEL, BATCH OR SERIAL NUMBER :

*ELECTRIC PUNCHING / BINDING MACHINE, MODEL PUNCH-BIND ER*

**ISSUE 1, January 2003**

Serial number PB.001 onwards

SERIAL NUMBER :

**In application of machines directives : 98/37/CEE**

**In application of directive CEM n° 89/336/CEE**

**In application of directive -low tension n° 73/23/EEC**

Standards used :

*EN 60204-1* 1998 - Safety of machinery, electrical equipment of machines

*EN 60950* 1992 - Safety of information technology equipment, including electrical business equipment

*EN 294* 1992 - Safty distance

*EN 50081-1* 1992 - Emission of electronic disturbances (class B)

*EN 50082-1* 1993 - Immunity to electromagnetic disturbances (class B)

Place of issue : **L'Aigle, France.**

Name of authorised representatives : **Guy VATOME**

Position : *General Manager*

I declare as the authorised representative that the above information in relation to the supply / manufacture of this product complies with all the essential health and safety requirements of the EC Machinery Directive 89/392/EEC – 89/368/EEC – 73/23/EEC – low Voltage – and EMC machinery Directive 89/336CEEB and as amended with the national laws and regulations adopting this Directive.

Date :

Signature :